

# Standard Type Full Cone Spray Nozzles

# JJXP

Full Cone

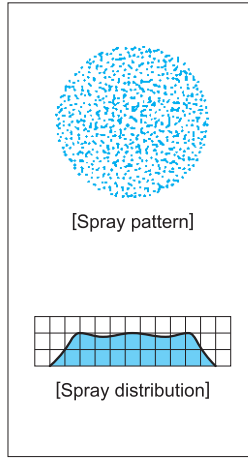
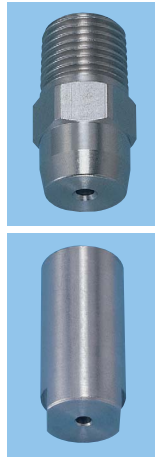

### [Features]

- Full cone spray pattern with a round impact area and uniform distribution.
- Spray capacity ranges from small to medium.
- X-shaped whirler provides large free passage diameter for minimal clogging.

### [Standard Pressure]

0.2 MPa

### [Applications]

- Cleaning: Gas, incinerator fumes, machinery, eliminators, screen, tanks, parts, crushed stones, earth and sand
- Cooling: Gas, machineries, tanks, steels
- Spraying: Waste water treatment, aeration, foam breaking, fire extinguishing, dust suppression, sea water desalination

## JJXP series

JJXP series	
Structure	● One-piece structure with press-fit X-shaped whirler.
Material	<ul style="list-style-type: none"> <li>● Sizes <math>\frac{1}{8}M</math>–<math>\frac{3}{4}M</math> (<math>\frac{3}{4}F</math>): S303</li> <li>● Sizes <math>\frac{1}{2}F</math>–<math>1F</math>: S303 or B (brass)</li> <li>● Sizes <math>1\frac{1}{2}F</math> or larger: S316</li> <li>● Whirler material is mainly S316L equivalent, but depending on nozzle codes, S316 equivalent or SCS16 whirlers are used.</li> <li>● Optional material: S316, S316L PP, PTFE (for <math>\frac{3}{4}F</math> sizes and over)</li> </ul> <p>[Note] Thread size of optional material may differ depending on materials.</p>

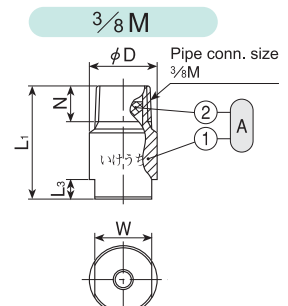
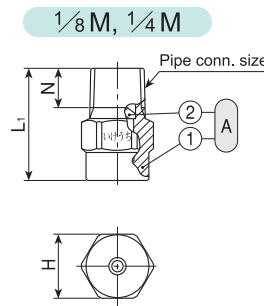
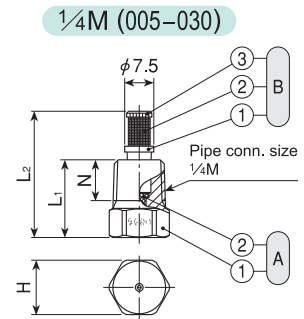
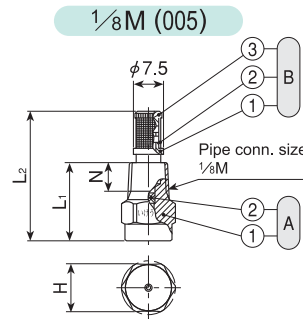

Pipe conn. size*1	Dimensions (mm)							Mass (g)	
	L <sub>1</sub>	L <sub>2</sub>	L <sub>3</sub>	H	W	φD	N	S303 S316	B
$\frac{1}{8}M$ (005)	32.5	20	—	12	—	—	7	9.5*2	—
$\frac{1}{8}M$ (010-030)	20	—	—	12	—	—	7	11	—
$\frac{1}{4}M$ (005-030)	20	32.5	—	14	—	—	10.5	18	—
$\frac{1}{4}M$ (040-060)	28	—	—	14	—	—	10.5	21	—
$\frac{3}{8}M$	34	—	6	—	17	20	11	50	—
$\frac{3}{8}F$	43	—	6	—	17	20	11	61	—
$\frac{1}{2}F$	54	—	8	—	22	25	14	140	150
$\frac{3}{4}F$	69	—	10	—	27	32	15	270	290
1F	89	—	14	—	34	40	17	515	550
$1\frac{1}{2}F$	124	—	20	—	50	58	19	1,520	—
2F (250-350)	160	—	24	—	60	70	23	2,600	—
2F (400-500)	118.5	—	24	—	60	70	23	2,050	—
$2\frac{1}{2}F$	147.5	—	27	—	80	90	27	4,360	—
3F (920)	163.5	—	30	—	90	105	30	6,700	—
3F (1200)	170.5	—	30	—	90	105	30	6,500	—

\*1) Figures in ( ) after the pipe connection sizes indicate the spray capacity codes.  
\*2) For JJXP005 with strainer, add 2 g to the above mass.

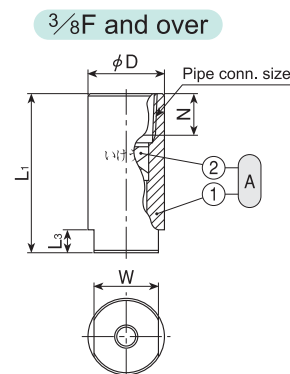

- A Nozzle** (1)Body (2)Whirler [S316L equivalent])  
**B Strainer** (1)Strainer holder (2)Strainer screen [S316] (3)Strainer cap

[Note] Appearance and dimensions may differ slightly depending on materials and nozzle codes.

## Standard Type Full Cone Spray Nozzles JJXP series

Full Cone

Spray Capacity Code	Pipe Conn. Size				Spray Angle (°)			Spray Capacity (ℓ/min)									Mean Drop. Dia. (μm)	Free Pass. Dia. (mm)
	1/8M	1/4M	3/8M	1/2M	0.05 MPa	0.2 MPa	0.5 MPa	0.03 MPa	0.05 MPa	0.1 MPa	0.15 MPa	0.2 MPa	0.3 MPa	0.5 MPa	0.7 MPa	1 MPa		
005	●	●			—	55	65	—	—	0.36	0.44	0.50	0.59	0.73	0.83	0.96	270	0.4
010	○	○			50	55	45	—	0.53	0.73	0.88	1.00	1.18	1.45	1.67	1.93	290	0.7
015	○	○			60	65	55	—	0.79	1.09	1.31	1.50	1.77	2.18	2.50	2.89	§	0.8
020	○	○			60	65	55	—	1.06	1.46	1.75	2.00	2.36	2.91	3.34	3.86	§	1.4
030	○	○			65	70	60	—	1.59	2.18	2.63	3.00	3.54	4.36	5.00	5.79	410	1.4
040		○			60	65	55	—	2.12	2.91	3.51	4.00	4.72	5.81	6.67	7.72	380	1.7
050		○			65	70	60	—	2.65	3.64	4.38	5.00	5.90	7.27	8.34	9.64	§	1.7
060		○			70	75	65	2.51	3.18	4.37	5.26	6.00	7.08	8.72	10.0	11.6	520	1.7
070			○	○	60	65	60	2.93	3.71	5.09	6.13	7.00	8.26	10.2	11.7	13.5	480	1.9
080			○	○	65	70	65	3.35	4.24	5.82	7.01	8.00	9.44	11.6	13.3	15.4	§	1.9
10			○	○	75	80	75	4.19	5.29	7.28	8.76	10.0	11.8	14.5	16.7	19.3	§	2.6
12			○	○	80	85	80	5.03	6.35	8.73	10.5	12.0	14.2	17.4	20.0	23.1	660	2.6

Spray Capacity Code	Pipe Conn. Size							Spray Angle (°)			Spray Capacity (ℓ/min)									Mean Drop. Dia. (μm)	Free Pass. Dia. (mm)
	1/2F	3/4F	1F	1 1/2F	2F	2 1/2F	3F	0.05 MPa	0.2 MPa	0.5 MPa	0.03 MPa	0.05 MPa	0.1 MPa	0.15 MPa	0.2 MPa	0.3 MPa	0.5 MPa	0.7 MPa	1 MPa		
14	○							65	70	55	5.86	7.41	10.2	12.3	14.0	16.5	20.3	23.3	27.0	590	3.5
16	○							70	75	60	6.70	8.47	11.6	14.0	16.0	18.9	23.3	26.7	30.9	§	3.5
18	○							75	80	65	7.54	9.53	13.1	15.8	18.0	21.2	26.2	30.0	34.7	§	3.5
20	○							80	85	70	8.38	10.6	14.6	17.5	20.0	23.6	29.1	33.4	38.6	740	3.5
23		○						70	75	60	9.63	12.2	16.7	20.2	23.0	27.1	33.4	38.4	44.4	630	4.7
26		○						75	80	65	10.9	13.8	18.9	22.8	26.0	30.7	37.8	43.4	50.1	§	4.7
30		○						80	85	70	12.6	15.9	21.8	26.3	30.0	35.4	43.6	50.0	57.9	§	4.7
35		○						85	90	75	14.7	18.5	25.5	30.7	35.0	41.3	50.9	58.4	67.5	§	4.7
40		○						90	95	80	16.8	21.2	29.1	35.1	40.0	47.2	58.1	66.7	77.2	§	4.7
45		○						90	95	80	18.8	23.8	32.7	39.4	45.0	53.1	65.4	75.0	86.8	950	4.7
50			○					70	75	60	20.9	26.5	36.4	43.8	50.0	59.0	72.7	83.4	96.4	800	6.0
60			○					80	85	70	25.1	31.8	43.7	52.6	60.0	70.8	87.2	100	116	§	6.0
80			○					90	95	80	33.5	42.4	58.2	70.1	80.0	94.4	116	133	154	§	6.0
90			○					90	95	80	37.7	47.7	65.5	78.9	90.0	106	131	150	174	1,150	6.6
100				○				80	85	70	41.9	52.9	72.8	87.6	100	118	145	167	193	1,000	8.4
150				○				85	90	75	62.8	79.4	109	131	150	177	218	250	289	§	10.3
200				○				90	95	80	83.8	106	146	175	200	236	291	334	386	1,350	10.3
250					○			85	90	75	105	132	182	219	250	295	363	417	482	1,200	12.7
300					○			90	95	80	126	159	218	263	300	354	436	500	579	§	12.7
350					○			90	95	80	147	185	255	307	350	413	509	584	675	§	12.7
400					○			75	80	65	168	212	291	351	400	472	581	667	772	§	13.2
500					○			95	95	80	209	265	364	438	500	590	727	834	964	1,500	13.2
600						○		75	80	65	251	318	437	526	600	708	872	1,001	1,157	1,500	16.9
700						○		85	90	75	293	371	509	613	700	826	1,017	1,167	1,350	1,800	16.9
920							○	100	100	85	385	487	669	806	920	1,086	1,337	1,534	1,775	1,660	18.1
1200							○	105	105	90	503	635	873	1,052	1,200	1,416	1,744	2,001	2,315	1,950	20.0

●.....With strainer (#100 mesh only)    ○.....Without strainer

For spraying slurry, the nozzle material should be wear-resistant. For this purpose, the [JUXP-AL92 series] nozzles made of 92% alumina are available (see page 66).

### How to order

Please inquire or order for a specific nozzle using this coding system.

⟨Example⟩...1/8MJJXP005S303W

1/8M	JJXP	005	S303	W
Pipe Conn. Size (*3)		Spray Capacity Code	Material (*4)	Strainer
1/8M		005	S303	W (with Strainer: JJXP005 only)
§		§	B	- (without Strainer)
3F		1200	S316	

\*3) When spray capacity code is 005–030, pipe connection size for 1/4M is indicated as "1/4x1/8M".

\*4) See "Material" information on page 57 for standard materials by each size.

# Standard Type Full Cone Spray Nozzles

## JJXP-PP / JJXP-PVDF

Full Cone

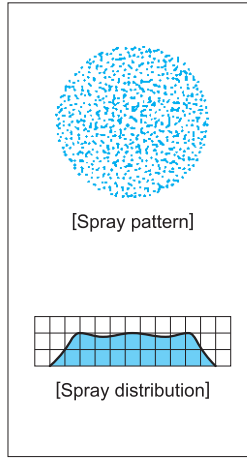

### [Features]

- Full cone spray pattern with a round impact area and uniform distribution.
- X-shaped whirler provides large free passage diameter for minimal clogging.

### [Standard Pressure]

0.2 MPa

### [Applications]

- Cleaning: Machinery, screens, tanks, crushed stones, earth and sand
- Cooling: Machinery, tanks
- Spraying: Waste water treatment, aeration, foam breaking, dust suppression, etching, chemicals

### JJXP-PP series

JJXP-PP series	
Structure	• One-piece structure with press-fit X-shaped whirler.
Material	• PP (polypropylene)
Mass	• Size 1/2F: 25.3 g • 3/4M: 17.9 g

#### [Note]

- Appearance and dimensions may differ slightly depending on materials and nozzle codes.
- Please note that the position of standard diameter for male thread type has been changed.

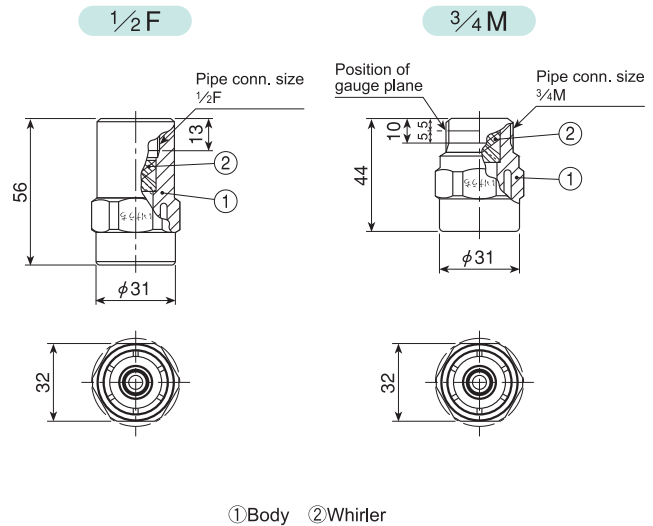

### JJXP-PVDF series

JJXP-PVDF series	
Structure	• One-piece structure with press-fit X-shaped whirler.
Material	• PVDF (polyvinylidene fluoride)

Pipe conn. size	Dimensions (mm)				Mass (g)
	L	H	φD	N	
1/8 M	18	12	11	8	2.2
1/4 M	22	14	12	11.5	4.1

[Note] Appearance and dimensions may differ slightly depending on materials and nozzle codes.

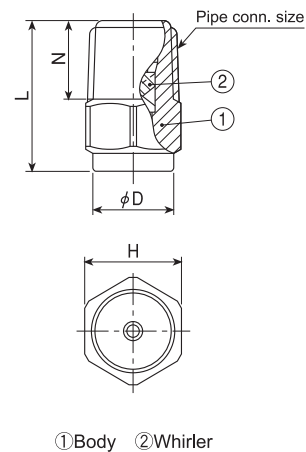

## Standard Type Full Cone Spray Nozzles JJXP-PP / JJXP-PVDF series

Full Cone

### JJXP-PP series

Spray Capacity Code	Pipe Conn. Size		Spray Angle (°)			Spray Capacity (ℓ/min)									Mean Drop. Dia. (μm)	Free Pass. Dia. (mm)
	1/2F	3/4M	0.05 MPa	0.2 MPa	0.5 MPa	0.03 MPa	0.05 MPa	0.1 MPa	0.15 MPa	0.2 MPa	0.3 MPa	0.5 MPa	0.7 MPa	1 MPa		
2 <sup>100</sup> / <sub>2</sub>		○	96	100	92	5.03	6.35	8.73	10.5	12.0	14.2	17.4	20.0	23.1	570	3.1
2 <sup>100</sup> / <sub>3</sub>		○	96	100	92	5.44	6.88	9.46	11.4	13.0	15.3	18.9	21.7	25.1		3.1
2 <sup>100</sup> / <sub>4</sub>	○	○	96	100	92	5.86	7.41	10.2	12.3	14.0	16.5	20.3	23.3	27.0		3.5
2 <sup>100</sup> / <sub>5</sub>	○	○	96	100	92	6.28	7.94	10.9	13.1	15.0	17.7	21.8	25.0	28.9	∫	3.5
2 <sup>100</sup> / <sub>6</sub>	○	○	96	100	92	6.70	8.47	11.6	14.0	16.0	18.9	23.3	26.7	30.9		3.5
2 <sup>100</sup> / <sub>8</sub>	○	○	96	100	92	7.54	9.53	13.1	15.8	18.0	21.2	26.2	30.0	34.7		3.5
2 <sup>100</sup> / <sub>20</sub>	○	○	96	100	92	8.38	10.6	14.6	17.5	20.0	23.6	29.1	33.4	38.6	740	3.5

### JJXP-PVDF series

Spray Capacity Code	Pipe Conn. Size		Spray Angle (°)			Spray Capacity (ℓ/min)									Mean Drop. Dia. (μm)	Free Pass. Dia. (mm)
	1/8M	1/4M	0.05 MPa	0.2 MPa	0.5 MPa	0.03 MPa	0.05 MPa	0.1 MPa	0.15 MPa	0.2 MPa	0.3 MPa	0.5 MPa	0.7 MPa	1 MPa		
010	○	○	60	65	55	—	0.53	0.73	0.88	1.00	1.18	1.45	1.67	1.93	290	0.8
015	○	○	60	65	55	—	0.79	1.09	1.32	1.50	1.77	2.18	2.50	2.89		1.0
020	○	○	60	65	55	—	1.06	1.46	1.75	2.00	2.36	2.91	3.34	3.86	∫	1.5
025	○	○	60	65	55	—	1.32	1.82	2.20	2.50	2.95	3.62	4.17	4.82		1.5
030	○	○	60	65	55	—	1.59	2.18	2.63	3.00	3.54	4.36	5.00	5.79	410	1.5

### How to order

Please inquire or order for a specific nozzle using this coding system.

#### ① JJXP-PP series

〈Example〉...1/2FJJXP 2<sup>100</sup>/<sub>14</sub> PP

1/2F	JJXP	2 <sup>100</sup> / <sub>14</sub>	PP
Pipe Conn. Size 1/2 F 3/4 M		Spray Capacity Code 2 <sup>100</sup> / <sub>12</sub> ∫ 2 <sup>100</sup> / <sub>20</sub>	

#### ② JJXP-PVDF series

〈Example〉...1/8MJJXP010PVDF

1/8M	JJXP	010	PVDF
Pipe Conn. Size 1/8 M 1/4 x 1/8 M(*1)		Spray Capacity Code 010 ∫ 030	

\*1) Pipe Connection Size code for 1/4M is "1/4x1/8M" in JJXP-PVDF series.

# Standard Type Full Cone Spray Nozzles

## JJXP-HTPVC/JJXP-PVC

For spraying chemicals such as hydrochloric acid, heat-treated HTPVC injection-molded **JJXP-HTPVC series** nozzles are available.

Full Cone

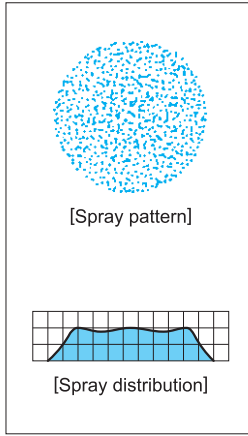

### [Features]

- Full cone spray pattern with a round impact area and uniform distribution.
- X-shaped whirler provides large free passage diameter for minimal clogging.
- X-shaped whirler is removable for easy maintenance.

### [Standard Pressure]

0.2 MPa

### [Applications]

Spraying: Etchants, chemicals  
Cleaning: Printed circuit boards

### JJXP-HTPVC series

JJXP-HTPVC series	
Structure	● One-piece structure with removable X-shaped whirler.
Material	● HTPVC (heat-treated polyvinyl chloride)
Mass	● 2.5 g

[Note] Appearance and dimensions may differ slightly depending on materials and nozzle codes.

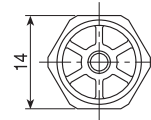
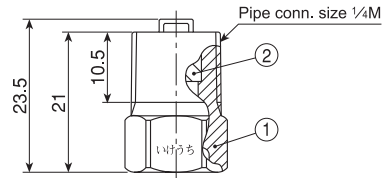

①Body ②Whirler

### JJXP-PVC series

JJXP-PVC series	
Structure	● One-piece structure with removable X-shaped whirler.
Material	● PVC (polyvinyl chloride)
Mass	● 1.4 g

[Note] Appearance and dimensions may differ slightly depending on materials and nozzle codes.

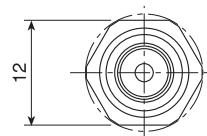
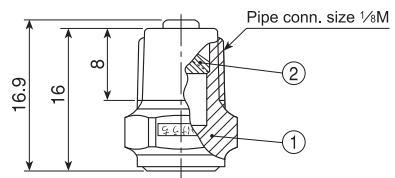

①Body ②Whirler

## Standard Type Full Cone Spray Nozzles JJXP-HTPVC / JJXP-PVC series

### ■ JJXP-HTPVC series

Spray Capacity Code	Spray Angle (°)			Spray Capacity (ℓ/min)									Mean Drop. Dia. (μm)	Free Pass. Dia. (mm)
	0.05 MPa	0.2 MPa	0.5 MPa	0.03 MPa	0.05 MPa	0.1 MPa	0.15 MPa	0.2 MPa	0.3 MPa	0.5 MPa	0.7 MPa	1 MPa		
040	60	65	55	—	2.12	2.91	3.51	4.00	4.72	5.81	6.67	7.72	380	2.2
050	65	70	60	—	2.65	3.64	4.38	5.00	5.90	7.27	8.34	9.64	5	2.2
060	70	75	65	2.51	3.18	4.37	5.26	6.00	7.08	8.72	10.0	11.6	520	2.2

### ■ JJXP-PVC series

Spray Angle (°)			Spray Capacity (ℓ/min)									Mean Drop. Dia. (μm)	Free Pass. Dia. (mm)
0.05 MPa	0.2 MPa	0.5 MPa	0.03 MPa	0.05 MPa	0.1 MPa	0.15 MPa	0.2 MPa	0.3 MPa	0.5 MPa	0.7 MPa	1 MPa		
70	75	66	—	1.06	1.46	1.75	2.00	2.36	2.91	3.34	3.86	350	1.5

### How to order

Please inquire or order for a specific nozzle using this coding system.

#### ① JJXP-HTPVC series

〈Example〉... 1/4MJJXP040HTPVC

1/4M JJXP **040** HTPVC

Spray Capacity Code
040
050
060

#### ② JJXP-PVC series

1/8M JJXP 2-75/2 PVC

# Effective Use of Full Cone Spray Nozzles

## Clogging and Free Passage Diameter

In order to form uniform distribution, full cone spray nozzles are usually fitted with whirlers and this part is the bottleneck of the liquid passage, where clogging problems often occur. Whirlers have several shapes such as X-shaped, disc-shaped and spiral-shaped ones, and the diameter of a sphere that can pass through the whirler is defined as free passage diameter.

As compared with other whirlers, the **X-shaped whirler** has a larger free passage diameter, which minimizes clogging. Some full cone nozzles without whirlers have been developed to eliminate clogging problems, such as the **AJP series** nozzle which features minimal clogging.



X-shaped whirler

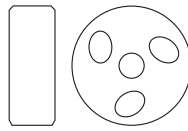

Disc whirler

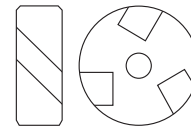

Spiral-shaped whirler

## Wear and Corrosion Resistance

If the liquid contains slurry, the inside of the nozzle exposed to the flow of liquid at high speed will wear out relatively quickly. For these applications, the **JUP series** nozzle is ideal, as the orifice and whirler are made of ceramics. **JUXP, AJP-AL92 and TJJX-SiC series** nozzles are more effective as all parts are made of ceramics. For corrosive applications, nozzles made of special materials such as plastics and titanium alloy are available.

## Mass Savings

For arrangements of many large size nozzles, mass savings of the nozzles affects the total production cost for the systems. The **TJJX series** nozzle with a newly developed X-shaped whirler has a 20% shorter overall length and 20% less mass than conventional nozzles. In addition, the mass of TJJX-SiC series nozzle (made of silicon nitride bonded silicon carbide) is less than half of metal nozzles.

## Rotation Reaction Force

In full cone spray nozzles with whirlers, rotation torque is generated as a reaction force by the vortex current produced by the whirler, which is determined by the following equation.

$$T \approx C \cdot Q \cdot D \cdot \sqrt{P}$$

[Example]

Nozzle No.	Torque at pressure of 0.2 MPa
¾FJJXP23	0.025 N-m
6TJJX4000	3,000 N-m

T: Torque (N-m)

C: Constant

Q: Spray capacity (ℓ/min)

D: External dimension of whirler (mm)

P: Spray pressure (MPa)

## Viscosity

As the viscosity of the liquid increases, generally spray capacity and angle decreases, spray distribution deteriorates and spray droplet size becomes larger.

(Spray capacity of hollow cone spray nozzles increases as the viscosity of liquid increases.

See page 55 for details.)

[Relation between viscosity and spray capacity]

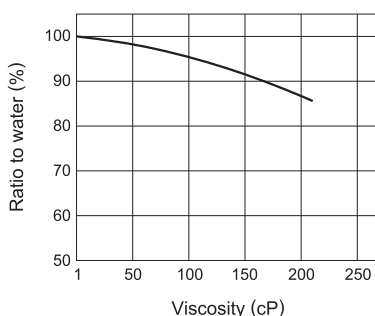

[Relation between viscosity and spray angle]

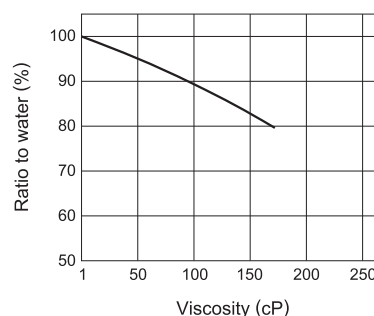

Nozzle tested: JJXP90  
Pressure: 0.02–0.03 MPa

# Quick-detachable Standard Full Cone Spray Nozzles

# INJJX

Patented

Full Cone

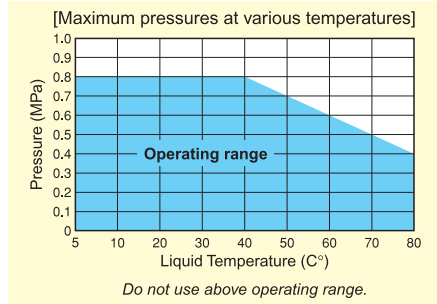
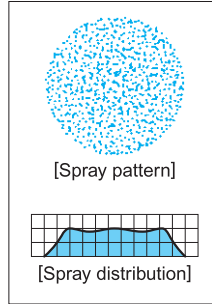

### [Features]

- Full cone spray nozzle with a removable whirler.
- Made in highly chemical and heat resistant PP (nozzle tip) and PPS (adaptor).
- Quick installation and removal by just turning the nozzle 60° by hand.
- Nozzle bodies are color-coded by spray capacity for easy identification.

### [Standard Pressure]

0.2 MPa

### [Applications]

- Cleaning • Etching
- Stripping • Chemical treatment
- For periodic maintenance or for the applications where precise spray alignment is required

## INJJX series

INJJX series	
Structure	<ul style="list-style-type: none"> <li>• Two-piece structure comprising nozzle and adaptor.</li> <li>• Easy installation and removal by just turning the nozzle 60°.</li> </ul>
Material	<ul style="list-style-type: none"> <li>• Nozzle: PP</li> <li>• Adaptor: PPS</li> <li>• Packing: FEPM</li> </ul>

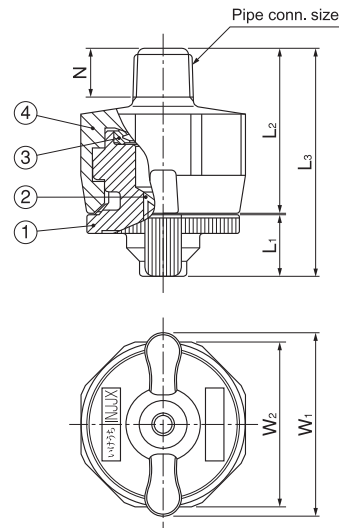

Pipe conn. size	Dimensions (mm)						Mass (g)
	L <sub>1</sub>	L <sub>2</sub>	L <sub>3</sub>	W <sub>1</sub>	W <sub>2</sub>	N	
1/8M	10	27	37	30	27	8	12
1/4M	10	30	40	30	27	11.5	13
3/8M	10	30	40	30	27	12	14

[Note]  
• Appearance and dimensions may differ slightly depending on materials and nozzle codes.

• **INJJX series nozzles are not compatible with the discontinued ISJJX series.**

①Body ②Whirler ③Packing ④Adaptor

Spray Capacity Code	Pipe Conn. Size			Spray Angle (°)			Spray Capacity (ℓ/min)							Mean Drop. Dia. (μm)	Free Pass. Dia. (mm)	Color of Nozzle Body	
	1/8M	1/4M	3/8M	0.05 MPa	0.2 MPa	0.5 MPa	0.03 MPa	0.05 MPa	0.1 MPa	0.15 MPa	0.2 MPa	0.3 MPa	0.5 MPa				0.7 MPa
010	○	○	○	60	65	55	—	0.53	0.73	0.88	1.00	1.18	1.45	1.67	}	0.8	Green
015	○	○	○	60	65	55	—	0.79	1.09	1.32	1.50	1.77	2.18	2.50		1.0	Yellow
020	○	○	○	60	65	55	—	1.06	1.46	1.75	2.00	2.36	2.91	3.34		1.5	Grey
025	○	○	○	60	65	55	—	1.32	1.82	2.20	2.50	2.95	3.62	4.17		1.5	Orange
030	○	○	○	60	65	55	—	1.59	2.18	2.63	3.00	3.54	4.36	5.00		1.5	Blue
040	○	○	○	60	65	55	—	2.12	2.91	3.51	4.00	4.72	5.81	6.67		2.0	Purple
050	○	○	○	65	70	60	—	2.65	3.64	4.38	5.00	5.90	7.27	8.34	2.0	Light Green	
060	○	○	○	70	75	65	2.51	3.18	4.37	5.26	6.00	7.08	8.72	10.0	520	2.0	Pink

**How to order** Please inquire or order for a specific nozzle using this coding system.

#### ① Complete unit

<Example> ...1/8M(PT)INJJX040PP(FEPM)+PPS

1/8M (PT) INJJX 040 PP (FEPM) + PPS

Pipe Conn. Size	Thread type	Spray Capacity Code
1/8M	(PT)	010
1/4M	(NPT)	5
3/8M		060

#### ② Nozzle only

<Example> ... INJJX040PP(FEPM)

INJJX 040 PP (FEPM)

Spray Capacity Code
010
5
060

ALSO AVAILABLE!

Quick-detachable Standard Flat Spray Nozzles

## INVV series

See p.21 of this catalog.



# Ceramic Orifice and Whirler Inserted Full Cone Spray Nozzles

JUP

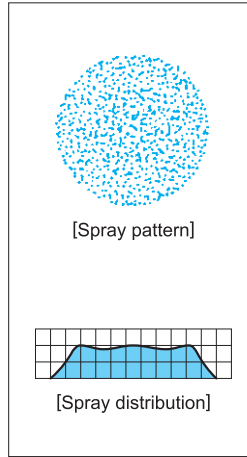

### [Features]

- Full cone spray pattern with a round impact area and uniform distribution.
- Ceramic disc whirler and ceramic orifice forming vortex chamber provide excellent wear resistance.
- Medium spray capacity is available.

### [Standard Pressure]

0.2 MPa

### [Applications]

Cleaning: Gas, incinerator fumes, machinery, eliminators, screen, tanks, crushed stones, earth and sand

Cooling: Gas, machinery, tanks, steels

Spraying: Waste water treatment, aeration, foam breaking, dust suppression

Full Cone

## JUP series

JUP series (with ceramic orifice inserted)	
Structure	● One-piece structure with ceramic whirler and orifice forming vortex chamber.
Material	<ul style="list-style-type: none"> <li>● Sizes 1F or smaller: S303 or B (brass)</li> <li>● Sizes 1½F or larger: S316</li> <li>● Optional material: S316L</li> </ul>

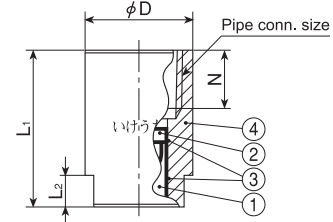

Pipe conn. size	Dimensions (mm)					Mass (g)	
	L <sub>1</sub>	L <sub>2</sub>	W	φD	N	S303 S316	B
⅜F	30	6	17	20	11	41	44
½F	39	8	22	25	14	115	125
¾F	49	10	27	32	15	167	177
1F	59	14	34	40	17	300	320
1½F	80	20	50	58	19	860	—

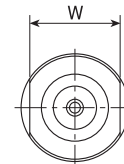

- ① Ceramic orifice
- ② Ceramic whirler
- ③ Adhesive: Araldite®
- ④ Body

[Note] Appearance and dimensions may differ slightly depending on materials and nozzle codes.

Spray Capacity Code	Pipe Conn. Size					Spray Angle (°)			Spray Capacity (ℓ/min)						Mean Drop. Dia. (μm)	Free Pass. Dia. (mm)	
	⅜F	½F	¾F	1F	1½F	0.05 MPa	0.2 MPa	0.5 MPa	0.03 MPa	0.05 MPa	0.1 MPa	0.15 MPa	0.2 MPa	0.3 MPa			0.5 MPa
03	○					50	60	52	—	1.57	2.17	2.62	3.00	3.55	4.37	380	1.2
04	○					50	60	52	—	2.09	2.89	3.50	4.00	4.73	5.83	5	1.4
05	○					55	65	55	—	2.61	3.61	4.37	5.00	5.91	7.29	490	1.5
06		○				50	60	52	2.46	3.13	4.33	5.24	6.00	7.09	8.75	470	2.0
07		○				55	63	55	2.87	3.65	5.05	6.12	7.00	8.27	10.2	5	2.0
08		○				55	65	55	3.28	4.18	5.78	6.99	8.00	9.46	11.7	5	2.0
10		○				60	70	58	4.10	5.22	7.22	8.74	10.0	11.8	14.6	5	2.2
12		○				63	70	60	4.92	6.26	8.66	10.5	12.0	14.2	17.5	600	2.3
14			○			63	70	60	5.74	7.31	10.1	12.2	14.0	16.5	20.4	580	2.8
16			○			63	70	60	6.56	8.35	11.6	14.0	16.0	18.9	23.3	5	2.8
18			○			70	77	65	7.38	9.40	13.0	15.7	18.0	21.3	26.2	5	3.0
20			○			75	80	68	8.20	10.4	14.4	17.5	20.0	23.6	29.2	5	3.0
23			○			75	80	68	9.43	12.0	16.6	20.1	23.0	27.2	33.5	5	3.2
26			○			78	83	70	10.7	13.6	18.8	22.7	26.0	30.7	37.9	5	3.2
30			○			78	83	72	12.3	15.7	21.7	26.2	30.0	35.5	43.7	730	3.4

# Ceramic Orifice and Whirler Inserted / Full Cone Spray Nozzles

## JUP series

Full Cone

Spray Capacity Code	Pipe Conn. Size					Spray Angle (°)			Spray Capacity (ℓ/min)							Mean Drop. Dia. (μm)	Free Pass. Dia. (mm)
	3/8F	1/2F	3/4F	1F	1 1/2F	0.05 MPa	0.2 MPa	0.5 MPa	0.03 MPa	0.05 MPa	0.1 MPa	0.15 MPa	0.2 MPa	0.3 MPa	0.5 MPa		
35				○		80	83	70	14.4	18.3	25.3	30.6	35.0	41.4	51.0	700	4.0
40				○		80	83	70	16.4	20.9	28.9	35.0	40.0	47.3	58.3		4.0
45				○		83	85	70	18.5	23.5	32.5	39.3	45.0	53.2	65.6	∫	4.0
50				○		83	85	72	20.5	26.1	36.1	43.7	50.0	59.1	72.9		4.0
55				○		83	85	72	22.6	28.7	39.7	48.1	55.0	65.0	80.2	900	4.0
60					○	75	80	70	24.6	31.3	43.3	52.4	60.0	70.9	87.5	800	5.0
70					○	78	83	70	28.7	36.5	50.5	61.2	70.0	82.7	102	∫	5.0
80					○	80	83	72	32.8	41.8	57.8	69.9	80.0	94.6	117		5.0
90					○	82	85	72	36.9	47.0	65.0	78.7	90.0	106	131	1,000	5.0

### How to order

Please inquire or order for a specific nozzle using this coding system.

〈Example〉... 3/8FJUP03S303

<b>3/8F</b>	<b>JUP</b>	<b>03</b>	<b>S303</b>
<small>Pipe Conn. Size</small>		<small>Spray Capacity Code</small>	<small>Material*</small>
■ 3/8F		■ 03	■ S303
∫		∫	■ B
■ 1 1/2F		■ 90	■ S316

\*See "Material" information on page 64 for standard materials by each size.

# Effective Use of Full Cone Spray Nozzles

## Clogging and Free Passage Diameter

In order to form uniform distribution, full cone spray nozzles are usually fitted with whirlers and this part is the bottleneck of the liquid passage, where clogging problems often occur. Whirlers have several shapes such as X-shaped, disc-shaped and spiral-shaped ones, and the diameter of a sphere that can pass through the whirler is defined as free passage diameter.

As compared with other whirlers, the **X-shaped whirler** has a larger free passage diameter, which minimizes clogging. Some full cone nozzles without whirlers have been developed to eliminate clogging problems, such as the **AJP series** nozzle which features minimal clogging.



X-shaped whirler

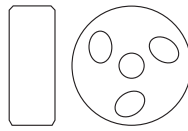

Disc whirler

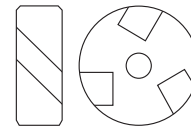

Spiral-shaped whirler

## Wear and Corrosion Resistance

If the liquid contains slurry, the inside of the nozzle exposed to the flow of liquid at high speed will wear out relatively quickly. For these applications, the **JUP series** nozzle is ideal, as the orifice and whirler are made of ceramics. **JUXP, AJP-AL92 and TJJX-SiC series** nozzles are more effective as all parts are made of ceramics. For corrosive applications, nozzles made of special materials such as plastics and titanium alloy are available.

## Mass Savings

For arrangements of many large size nozzles, mass savings of the nozzles affects the total production cost for the systems. The **TJJX series** nozzle with a newly developed X-shaped whirler has a 20% shorter overall length and 20% less mass than conventional nozzles. In addition, the mass of TJJX-SiC series nozzle (made of silicon nitride bonded silicon carbide) is less than half of metal nozzles.

## Rotation Reaction Force

In full cone spray nozzles with whirlers, rotation torque is generated as a reaction force by the vortex current produced by the whirler, which is determined by the following equation.

$$T \approx C \cdot Q \cdot D \cdot \sqrt{P}$$

[Example]

Nozzle No.	Torque at pressure of 0.2 MPa
¾FJJXP23	0.025 N-m
6TJJX4000	3,000 N-m

T: Torque (N-m)

C: Constant

Q: Spray capacity (ℓ/min)

D: External dimension of whirler (mm)

P: Spray pressure (MPa)

## Viscosity

As the viscosity of the liquid increases, generally spray capacity and angle decreases, spray distribution deteriorates and spray droplet size becomes larger.

(Spray capacity of hollow cone spray nozzles increases as the viscosity of liquid increases.

See page 55 for details.)

[Relation between viscosity and spray capacity]

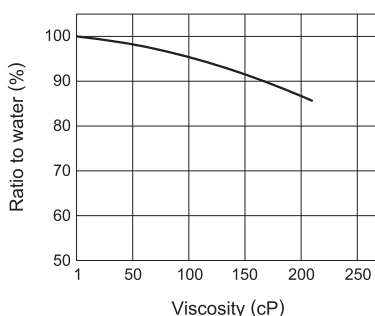

[Relation between viscosity and spray angle]

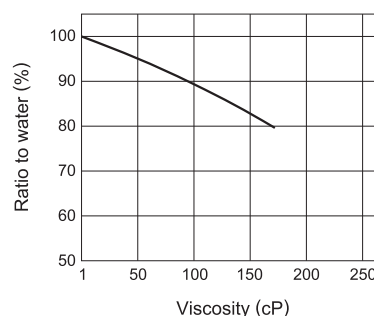

Nozzle tested: JJXP90  
Pressure: 0.02–0.03 MPa

# All Alumina Ceramic Full Cone Spray Nozzles

# JUXP-AL92

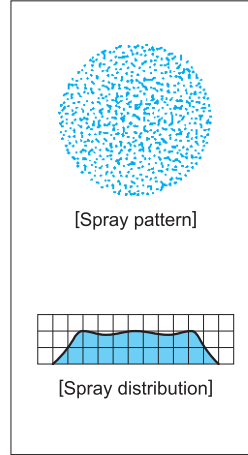

### [Features]

- X-shaped whirler provides large free passage diameter for minimal clogging.
- Made of high-purity alumina and provide excellent wear-resistance.
- Spray capacity ranges from medium to large.

### [Standard Pressure]

0.2 MPa

### [Applications]

- Absorption tower of flue gas desulfurization equipment.
- Spraying slurry

Full Cone

## JUXP-AL92 series

JUXP-AL92 series	
Structure	• Whole nozzle fired as one piece.
Material	• 92% Alumina

\* If installed into a metal header, this nozzle should be used with a socket made of S316, shown on page 85 (otherwise, the thread may be damaged). Please refer to page 85.

Pipe conn. size <sup>*1,2</sup>	Dimensions (mm)			Mass (g)
	L	φD	N	
1M	53	35	18	110
1½M	67	50	20	350
2M	100	65	24	760
2½M (250-350)	136	80	29	1,520
2½M (400-550)	94	80	29	1,130
3M	120	90	31	1,690

\*1) Figures in ( ) after the pipe connection sizes indicate the spray capacity codes.

[Note] Appearance and dimensions may differ slightly depending on materials and nozzle codes.

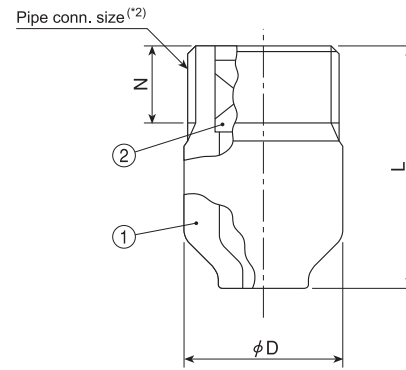

①Body ②Ceramic whirler

\*2) When used with our S316 socket, socket thread for pipe connection is female thread. Drawing for nozzle with socket is available on request. (The above drawing is nozzle only)

Spray Capacity Code	Pipe Conn. Size					Spray Angle (°)			Spray Capacity (ℓ/min)								Mean Drop. Dia. (μm)	Free Pass. Dia. (mm)	
	1M	1½M	2M	2½M	3M	0.05 MPa	0.2 MPa	0.5 MPa	0.03 MPa	0.05 MPa	0.1 MPa	0.15 MPa	0.2 MPa	0.3 MPa	0.5 MPa	0.7 MPa			1 MPa
23	○					70	75	60	9.63	12.2	16.7	20.2	23.0	27.1	33.4	38.4	44.4	630	4.7
26	○					75	80	65	10.9	13.8	18.9	22.8	26.0	30.7	37.8	43.4	50.1		4.7
30	○					80	85	70	12.6	15.9	21.8	26.3	30.0	35.4	43.6	50.0	57.9	5	4.7
35	○					85	90	75	14.7	18.5	25.5	30.7	35.0	41.3	50.9	58.4	67.5		4.7
40	○					90	95	80	16.8	21.2	29.1	35.1	40.0	47.2	58.1	66.7	77.2		4.7
45	○					90	95	80	18.8	23.8	32.7	39.5	45.0	53.1	65.4	75.0	86.8	950	4.7
50		○				70	75	60	20.9	26.5	36.4	43.8	50.0	59.0	72.7	83.4	96.4	800	6.0
55		○				75	80	65	23.0	29.1	40.0	48.2	55.0	64.9	79.9	91.7	105		6.0
60		○				80	85	70	25.1	31.8	43.7	52.6	60.0	70.8	87.2	100	115	5	6.0
70		○				85	90	75	29.3	37.1	50.9	61.4	70.0	82.6	100	120	135		6.0
80		○				90	95	80	33.5	42.4	58.2	70.1	80.0	94.4	115	135	155		6.6
90		○				90	95	80	37.7	47.7	65.5	78.9	90.0	106	130	150	175	1,150	6.6
100			○			80	85	70	41.9	52.9	72.8	87.7	100	120	145	170	195	1,000	8.7
120			○			80	85	70	50.3	63.5	82.3	105	120	140	175	200	230		8.7
150			○			85	90	75	62.8	79.4	110	130	150	180	220	250	290	5	8.7
180			○			90	95	80	75.4	95.3	130	160	180	210	260	300	350		10.3
200			○			90	95	80	83.8	105	145	175	200	240	290	335	385	1,350	10.7
250				○		85	90	75	105	130	180	220	250	295	360	420	480	1,200	12.7
300				○		90	95	80	125	160	220	265	300	355	435	500	580	5	12.7
350				○		90	95	80	150	185	255	310	350	415	510	585	675	1,450	12.7

All Alumina Ceramic / Full Cone Spray Nozzles

**JUXP-AL92 series**

Full Cone

Spray Capacity Code	Pipe Conn. Size					Spray Angle (°)			Spray Capacity (ℓ/min)									Mean Drop. Dia. (μm)	Free Pass. Dia. (mm)
	1M	1½M	2M	2½M	3M	0.05 MPa	0.2 MPa	0.5 MPa	0.03 MPa	0.05 MPa	0.1 MPa	0.15 MPa	0.2 MPa	0.3 MPa	0.5 MPa	0.7 MPa	1 MPa		
400				○		80	80	65	170	210	290	350	400	470	580	670	770	1,300	13.4
450				○		90	90	75	190	240	330	395	450	530	655	750	870	§	13.4
500				○		95	95	80	210	265	365	440	500	590	730	835	965		13.4
550				○		100	100	85	230	290	400	480	550	650	800	920	1,060	1,550	13.4
600					○	80	80	65	250	320	440	525	600	710	870	1,000	1,160	1,500	17.0
700					○	90	90	75	290	370	510	615	700	826	1,020	1,170	1,359	1,800	17.0

**How to order**

Please inquire or order for a specific nozzle using this coding system.

〈Example〉...1MJUXP23AL92

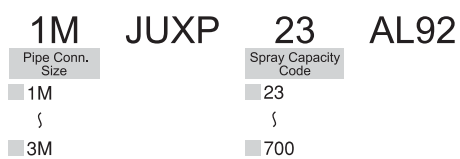

# Effective Use of Full Cone Spray Nozzles

## Clogging and Free Passage Diameter

In order to form uniform distribution, full cone spray nozzles are usually fitted with whirlers and this part is the bottleneck of the liquid passage, where clogging problems often occur. Whirlers have several shapes such as X-shaped, disc-shaped and spiral-shaped ones, and the diameter of a sphere that can pass through the whirler is defined as free passage diameter.

As compared with other whirlers, the **X-shaped whirler** has a larger free passage diameter, which minimizes clogging. Some full cone nozzles without whirlers have been developed to eliminate clogging problems, such as the **AJP series** nozzle which features minimal clogging.



X-shaped whirler

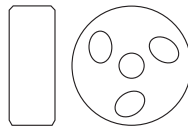

Disc whirler

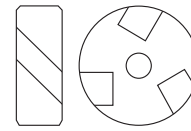

Spiral-shaped whirler

## Wear and Corrosion Resistance

If the liquid contains slurry, the inside of the nozzle exposed to the flow of liquid at high speed will wear out relatively quickly. For these applications, the **JUP series** nozzle is ideal, as the orifice and whirler are made of ceramics. **JUXP, AJP-AL92 and TJJX-SiC series** nozzles are more effective as all parts are made of ceramics. For corrosive applications, nozzles made of special materials such as plastics and titanium alloy are available.

## Mass Savings

For arrangements of many large size nozzles, mass savings of the nozzles affects the total production cost for the systems. The **TJJX series** nozzle with a newly developed X-shaped whirler has a 20% shorter overall length and 20% less mass than conventional nozzles. In addition, the mass of TJJX-SiC series nozzle (made of silicon nitride bonded silicon carbide) is less than half of metal nozzles.

## Rotation Reaction Force

In full cone spray nozzles with whirlers, rotation torque is generated as a reaction force by the vortex current produced by the whirler, which is determined by the following equation.

$$T \approx C \cdot Q \cdot D \cdot \sqrt{P}$$

[Example]

Nozzle No.	Torque at pressure of 0.2 MPa
¾FJJXP23	0.025 N-m
6TJJX4000	3,000 N-m

T: Torque (N-m)

C: Constant

Q: Spray capacity (ℓ/min)

D: External dimension of whirler (mm)

P: Spray pressure (MPa)

## Viscosity

As the viscosity of the liquid increases, generally spray capacity and angle decreases, spray distribution deteriorates and spray droplet size becomes larger.

(Spray capacity of hollow cone spray nozzles increases as the viscosity of liquid increases.

See page 55 for details.)

[Relation between viscosity and spray capacity]

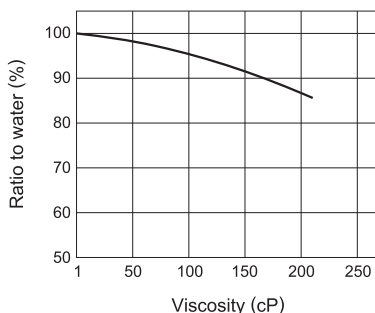

[Relation between viscosity and spray angle]

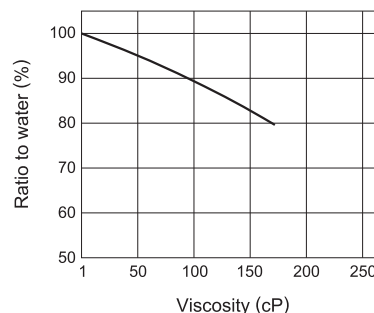

Nozzle tested: JJXP90  
Pressure: 0.02–0.03 MPa

7-head Full Cone Spray Nozzles / Standard type  
**7JJXP series**

Related Products

13JJXP series (13-head Full Cone Spray Nozzles)

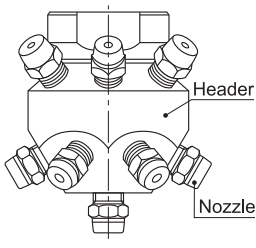
Series	Appearance	Structure	Features	Applications
13JJXP			<ul style="list-style-type: none"> <li>• Full cone spray pattern with uniform spray distribution.</li> <li>• 13 pcs. of JJXP series full cone spray nozzles are screwed into a very compact header.</li> <li>• Spray droplet diameter is smaller than those of other single-head full cone spray nozzles having the same spray capacity.</li> </ul>	<ul style="list-style-type: none"> <li>• Gas cooling</li> <li>• Moisture control</li> </ul>

Cone Spray

Socket for Alumina Nozzles

Optional socket available for alumina nozzles (AP-AL92, JUXP-AL92, AJP-AL92 series).

Material of socket: S316

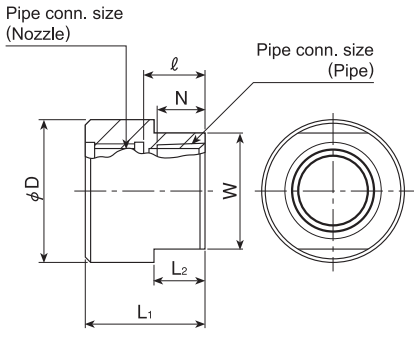

Nominal diameter	Pipe conn. size		Dimensions (mm)							Mass (g)
	Nozzle	Pipe	L <sub>1</sub>	L <sub>2</sub>	ℓ	W	φD	N		
1/2	1/2	1/2	34	10	18	27	30	14	120	
3/4	3/4	3/4	39	14	21	35	40	15	230	
3/4x1	1	3/4	41	18	21	41	50	15	200	
1	1	1	43	18	23	41	50	17	400	
1x1 1/2	1 1/2	1	47	24	24	60	70	17	560	
1 1/2	1 1/2	1 1/2	50	24	27	60	70	19	840	
1 1/2x2	2	1 1/2	54	27	27	70	80	19	680	
2	2	2	58	27	31	70	80	23	1,100	
2x2 1/2	2 1/2	2	62	30	31	90	100	23	1,400	
2 1/2	2 1/2	2 1/2	66	30	35	90	100	27	2,000	
2 1/2x3	3	2 1/2	71	35	36	100	110	27	1,500	
3	3	3	75	35	40	100	110	30	2,200	

\* Thread for connecting pipe is female taper thread.

# Small Capacity Full Cone Spray Nozzles

# JJRP

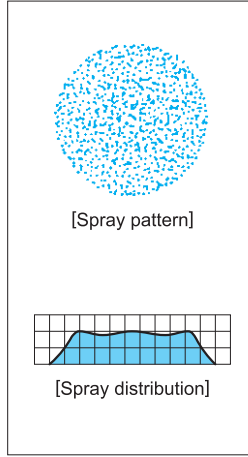

### [Features]

- Small capacity full cone spray nozzles made of excellent wear-resistant PTFE (polytetrafluoroethylene) and injection molded PVDF (polyvinylidene fluoride).
- Disc whirler is designed to provide uniform spray distribution at small spray capacity.

### [Standard Pressure]

0.2 MPa

### [Applications]

- Spraying: Etchants, acid liquids
- Cleaning: When spraying pure water

Full Cone

## JJRP series

JJRP series	
Structure	<ul style="list-style-type: none"> <li>• One-piece structure with press-fit disc whirler.</li> <li>• JJRP-PVDF nozzle body is injection molded.</li> </ul>
Material	<ul style="list-style-type: none"> <li>• PTFE (polytetrafluoroethylene), PVDF (polyvinylidene fluoride)</li> </ul>

Series	Pipe conn. size	Dimensions (mm)						Mass (g)
		L <sub>1</sub>	L <sub>2</sub>	H	W	φD	N	
JJRP-PTFE	1/8M	16	4	—	10	12	7	2
	1/4M	21	5	—	14	16	10.5	5
JJRP-PVDF	1/8M	18	10	12	—	11	8	2
	1/4M	22	10.5	14	—	12	11.5	4.1

[Note] Appearance and dimensions may differ slightly depending on materials and nozzle codes.

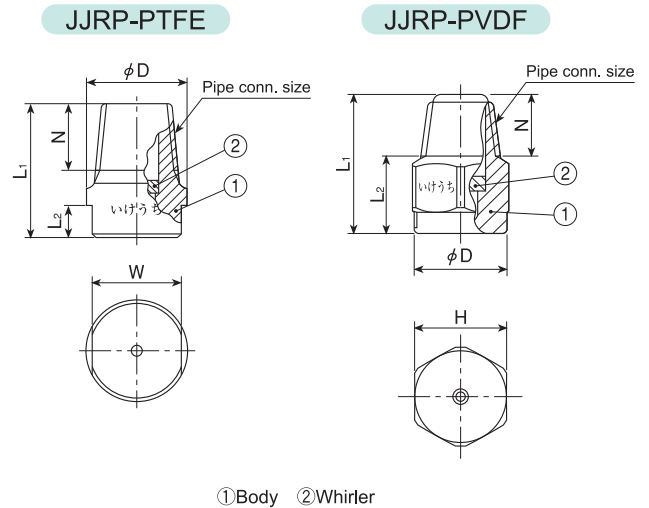

Spray Capacity Code	Pipe Connection Size				Spray Angle (°)			Spray Capacity (ℓ/min)								Mean Drop. Dia. (μm)	Free Pass. Dia. (mm)
	JJRP-PTFE		JJRP-PVDF					0.05 MPa	0.1 MPa	0.15 MPa	0.2 MPa	0.3 MPa	0.5 MPa	0.7 MPa	1 MPa		
	1/8M	1/4M	1/8M	1/4M	0.15 MPa	0.2 MPa	0.5 MPa	0.05 MPa	0.1 MPa	0.15 MPa	0.2 MPa	0.3 MPa	0.5 MPa	0.7 MPa	1 MPa		
005	○	○	○	○	56	60	60	—	0.36	0.44	0.50	0.59	0.74	0.85	0.99	260	0.4
007	○	○	○	○	60	65	62	—	0.51	0.61	0.70	0.83	1.03	1.19	1.39	260	0.6
010	○	○	○	○	63	65	62	—	0.73	0.88	1.00	1.19	1.48	1.70	1.98	260	0.8
015	○	○	○	○	64	70	72	0.79	1.09	1.31	1.50	1.78	2.22	2.56	2.98	260	1.0
020	○	○	○	○	64	70	72	1.06	1.45	1.75	2.00	2.38	2.95	3.41	3.97	410	1.2
030	○	○	○	○	75	80	78	1.58	2.18	2.63	3.00	3.56	4.43	5.11	5.95	410	1.3
040	○	○	○	○	67	70	65	2.11	2.91	3.50	4.00	4.75	5.91	6.82	7.93	380	1.4
050	○	○	○	○	76	80	70	2.64	3.63	4.38	5.00	5.94	7.38	8.52	9.92	380	1.6
060	○	○	○	○	88	90	80	3.17	4.36	5.26	6.00	7.13	8.86	10.2	11.9	520	1.6

\* Only the nozzles with white circle "○" in the above table are available.

### How to order

Please inquire or order for a specific nozzle using this coding system.

#### ① JJRP-PTFE series

〈Example〉...1/8MJJRP005PTFE

1/8M	JJRP	005	PTFE
<small>Pipe Conn. Size</small>		<small>Spray Capacity Code</small>	
1/8M		005	
1/4M <sup>(*)</sup>		060	

#### ② JJRP-PVDF series

〈Example〉...1/8MJJRP007PVDF

1/8M	JJRP	007	PVDF
<small>Pipe Conn. Size</small>		<small>Spray Capacity Code</small>	
1/8M		007	
1/4M <sup>(*)</sup>			

\*1) When Spray Capacity Code is 005-030, Pipe Connection Size for 1/4M is indicated as "1/4x1/8M".



# Effective Use of Full Cone Spray Nozzles

## Clogging and Free Passage Diameter

In order to form uniform distribution, full cone spray nozzles are usually fitted with whirlers and this part is the bottleneck of the liquid passage, where clogging problems often occur. Whirlers have several shapes such as X-shaped, disc-shaped and spiral-shaped ones, and the diameter of a sphere that can pass through the whirler is defined as free passage diameter.

As compared with other whirlers, the **X-shaped whirler** has a larger free passage diameter, which minimizes clogging. Some full cone nozzles without whirlers have been developed to eliminate clogging problems, such as the **AJP series** nozzle which features minimal clogging.



X-shaped whirler

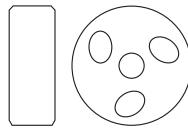

Disc whirler

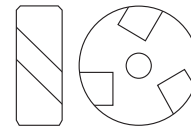

Spiral-shaped whirler

## Wear and Corrosion Resistance

If the liquid contains slurry, the inside of the nozzle exposed to the flow of liquid at high speed will wear out relatively quickly. For these applications, the **JUP series** nozzle is ideal, as the orifice and whirler are made of ceramics. **JUXP, AJP-AL92 and TJJX-SiC series** nozzles are more effective as all parts are made of ceramics. For corrosive applications, nozzles made of special materials such as plastics and titanium alloy are available.

## Mass Savings

For arrangements of many large size nozzles, mass savings of the nozzles affects the total production cost for the systems. The **TJJX series** nozzle with a newly developed X-shaped whirler has a 20% shorter overall length and 20% less mass than conventional nozzles. In addition, the mass of TJJX-SiC series nozzle (made of silicon nitride bonded silicon carbide) is less than half of metal nozzles.

## Rotation Reaction Force

In full cone spray nozzles with whirlers, rotation torque is generated as a reaction force by the vortex current produced by the whirler, which is determined by the following equation.

$$T \approx C \cdot Q \cdot D \cdot \sqrt{P}$$

[Example]

Nozzle No.	Torque at pressure of 0.2 MPa
¾FJJXP23	0.025 N-m
6TJJX4000	3,000 N-m

T: Torque (N-m)

C: Constant

Q: Spray capacity (ℓ/min)

D: External dimension of whirler (mm)

P: Spray pressure (MPa)

## Viscosity

As the viscosity of the liquid increases, generally spray capacity and angle decreases, spray distribution deteriorates and spray droplet size becomes larger.

(Spray capacity of hollow cone spray nozzles increases as the viscosity of liquid increases.

See page 55 for details.)

[Relation between viscosity and spray capacity]

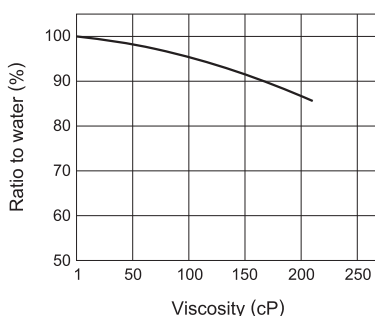

[Relation between viscosity and spray angle]

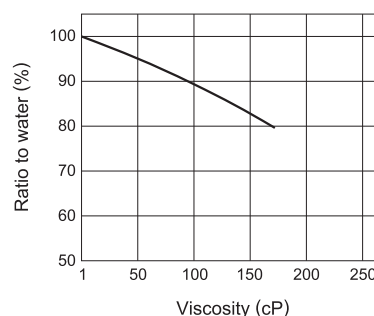

Nozzle tested: JJXP90  
Pressure: 0.02–0.03 MPa

# Small Capacity Full Cone Spray Nozzles



Full Cone

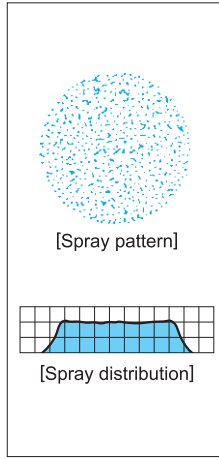

### [Features]

- Full cone spray pattern with a round impact area and uniform distribution.
- Features smallest spray capacity among full cone spray nozzles.
- Unique design developed from new engineering concept to produce fine atomization by impinging two inflows inside vortex chamber.
- Ceramic orifice and closer provide excellent wear-resistance.

### [Standard Pressure]

0.5 MPa for spray capacity codes of 006 and 008.  
0.2 MPa for spray capacity codes of 010 and over.

### [Applications]

Spraying: Oils, lubricants, glues, etchants  
Cleaning: Galvanizing, gas  
Cooling: Machinery, gas

## J series

J series (with ceramic orifice inserted)	
Structure	<ul style="list-style-type: none"> <li>● Spray orifice and closer are made of ceramics.</li> <li>● It can be disassembled into components.</li> <li>● All J series nozzles are equipped with built-in strainers.</li> </ul>
Material	<ul style="list-style-type: none"> <li>● Metal parts: S303 or B (brass)</li> <li>● Optional material: S316</li> </ul>
Mass	<ul style="list-style-type: none"> <li>● S303: 17.5 g</li> <li>● B (brass): 18.5 g</li> </ul>

[Note] Appearance and dimensions may differ slightly depending on materials and nozzle codes.

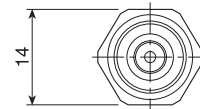
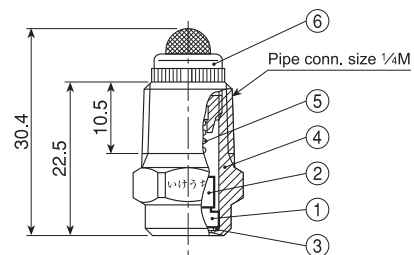

- ①Ceramic orifice ②Ceramic closer ③Packing (PTFE)  
④Body ⑤Spring (S316)  
⑥Strainer (S303+S304 or B+S304)

Spray Capacity Code	Spray Angle (°)			Spray Capacity (ℓ/min)									Mean Drop. Dia. (μm)	Free Pass. Dia. (mm)	Strainer Mesh Size
	0.1 MPa	0.2 MPa	0.5 MPa	0.1 MPa	0.15 MPa	0.2 MPa	0.3 MPa	0.5 MPa	0.7 MPa	1 MPa	1.5 MPa	2 MPa			
006	—	—	70	—	—	—	0.07	0.09	0.10	0.12	0.14	0.16	130	0.2	200
008	—	—	70	—	—	—	0.09	0.12	0.14	0.16	0.19	0.22	140	0.2	200
010	—	70	65	—	0.09	0.10	0.12	0.15	0.17	0.20	0.24	0.28	160	0.3	200
012	—	70	65	—	0.10	0.12	0.14	0.18	0.21	0.25	0.29	0.33	190	0.3	200
015	—	70	65	—	0.13	0.15	0.18	0.23	0.26	0.31	0.37	0.42	170	0.3	200
020	60	70	65	0.14	0.17	0.20	0.24	0.30	0.35	0.41	0.49	0.56	∫	0.3	200
025	65	70	67	0.18	0.22	0.25	0.30	0.38	0.44	0.51	0.61	0.70	230	0.3	200
030	67	70	68	0.22	0.26	0.30	0.36	0.45	0.52	0.61	0.73	0.83	220	0.4	150
040	67	70	68	0.29	0.35	0.40	0.48	0.60	0.70	0.82	0.98	1.11	∫	0.4	150
050	68	70	68	0.36	0.44	0.50	0.60	0.75	0.87	1.02	1.22	1.39	290	0.5	150
060	68	70	68	0.43	0.52	0.60	0.72	0.90	1.05	1.23	1.47	1.67	280	0.5	150
070	68	70	68	0.51	0.61	0.70	0.84	1.05	1.22	1.43	1.71	1.95	∫	0.6	150
080	68	70	68	0.58	0.70	0.80	0.95	1.19	1.38	1.61	1.92	2.18	350	0.7	150
100	68	70	68	0.72	0.87	1.00	1.19	1.49	1.72	2.01	2.40	2.72	∫	0.7	100
120	68	70	68	0.87	1.05	1.20	1.43	1.79	2.07	2.42	2.88	3.27	∫	0.8	50
140	68	70	68	1.01	1.22	1.40	1.67	2.09	2.41	2.82	3.36	3.81	440	0.9	50

### How to order

Please inquire or order for a specific nozzle using this coding system.

<Example>... 1/4MJ006NS303W

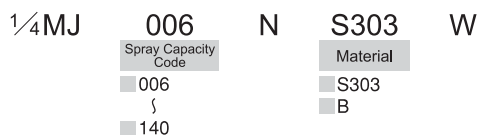

# Effective Use of Full Cone Spray Nozzles

## Clogging and Free Passage Diameter

In order to form uniform distribution, full cone spray nozzles are usually fitted with whirlers and this part is the bottleneck of the liquid passage, where clogging problems often occur. Whirlers have several shapes such as X-shaped, disc-shaped and spiral-shaped ones, and the diameter of a sphere that can pass through the whirler is defined as free passage diameter.

As compared with other whirlers, the **X-shaped whirler** has a larger free passage diameter, which minimizes clogging. Some full cone nozzles without whirlers have been developed to eliminate clogging problems, such as the **AJP series** nozzle which features minimal clogging.



X-shaped whirler

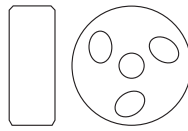

Disc whirler

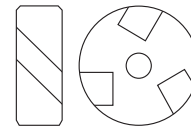

Spiral-shaped whirler

## Wear and Corrosion Resistance

If the liquid contains slurry, the inside of the nozzle exposed to the flow of liquid at high speed will wear out relatively quickly. For these applications, the **JUP series** nozzle is ideal, as the orifice and whirler are made of ceramics. **JUXP, AJP-AL92 and TJJX-SiC series** nozzles are more effective as all parts are made of ceramics. For corrosive applications, nozzles made of special materials such as plastics and titanium alloy are available.

## Mass Savings

For arrangements of many large size nozzles, mass savings of the nozzles affects the total production cost for the systems. The **TJJX series** nozzle with a newly developed X-shaped whirler has a 20% shorter overall length and 20% less mass than conventional nozzles. In addition, the mass of TJJX-SiC series nozzle (made of silicon nitride bonded silicon carbide) is less than half of metal nozzles.

## Rotation Reaction Force

In full cone spray nozzles with whirlers, rotation torque is generated as a reaction force by the vortex current produced by the whirler, which is determined by the following equation.

$$T \approx C \cdot Q \cdot D \cdot \sqrt{P}$$

[Example]

Nozzle No.	Torque at pressure of 0.2 MPa
¾FJJXP23	0.025 N-m
6TJJX4000	3,000 N-m

T: Torque (N-m)

C: Constant

Q: Spray capacity (ℓ/min)

D: External dimension of whirler (mm)

P: Spray pressure (MPa)

## Viscosity

As the viscosity of the liquid increases, generally spray capacity and angle decreases, spray distribution deteriorates and spray droplet size becomes larger.

(Spray capacity of hollow cone spray nozzles increases as the viscosity of liquid increases.

See page 55 for details.)

[Relation between viscosity and spray capacity]

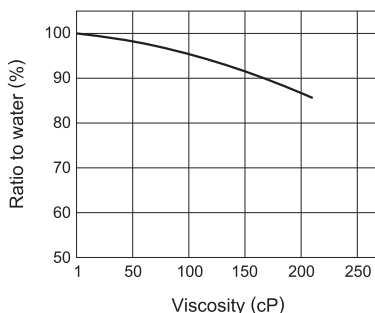

[Relation between viscosity and spray angle]

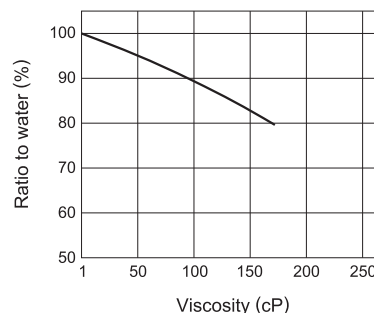

Nozzle tested: JJXP90  
Pressure: 0.02–0.03 MPa

# Flange-type, Large Capacity Full Cone Spray Nozzles

# TJJX

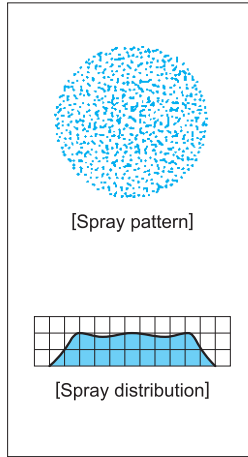

### [Features]

- Full cone spray pattern with a round impact area and uniform distribution.
- Flanged connection.
- X-shaped whirler provides large free passage diameter for minimal clogging.
- Adopting newly developed X-shaped whirler has shortened total length by 20% compared to conventional nozzles.

### [Standard Pressure]

0.2 MPa

### [Applications]

- Cooling: Gas, liquids
- Reacting: Chemical plants
- Spraying: Aeration, sea water desalination

Full Cone

## TJJX series

TJJX series	
Structure	<ul style="list-style-type: none"> <li>• One-piece structure with removable X-shaped whirler fixed to nozzle body by lock bolt.</li> <li>• Flanged connection.</li> </ul>
Material	<ul style="list-style-type: none"> <li>• SCS13 or SCS14 (Lock bolt: S316)</li> <li>• Optional material: SCS16</li> </ul>

Flange size	Dimensions (mm)					Flange (JIS 10K)		Mass (kg)
	L	$\phi D_1$	$\phi D_2$	$\phi D_3$	t	Qty. of bolt holes	$\phi$ (mm)	
4T	171	210	175	117	18	8	19	9.3
5T	211	250	210	143	20	8	23	11.4
6T	253	280	240	169	22	8	23	22.7

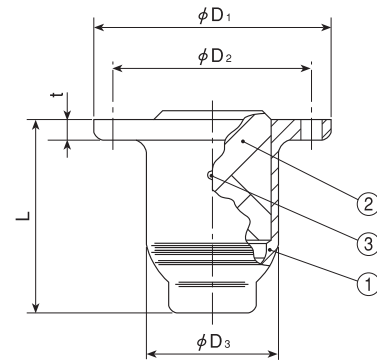

[Note] Appearance and dimensions may differ slightly depending on materials and nozzle codes.

①Body ②Whirler ③Lock bolt

Spray Capacity Code	Flange size			Spray Angle (°)			Spray Capacity (ℓ/min)						Mean Drop. Dia. (μm)	Free Pass. Dia. (mm)	
	4T	5T	6T	0.05 MPa	0.2 MPa	0.5 MPa	0.03 MPa	0.05 MPa	0.1 MPa	0.15 MPa	0.2 MPa	0.3 MPa			0.5 MPa
1500	○			90	90	75	628	794	1,091	1,315	1,500	1,770	2,180	1,850	29
2000	○			100	100	85	838	1,059	1,455	1,753	2,000	2,360	2,907		
2500		○		90	90	75	1,047	1,324	1,819	2,191	2,500	2,950	3,634	2,500	36
3000		○		100	100	85	1,257	1,588	2,183	2,629	3,000	3,540	4,361		
3500			○	90	90	75	1,466	1,853	2,547	3,067	3,500	4,130	5,087	2,650	44
4000			○	95	95	80	1,675	2,118	2,911	3,505	4,000	4,720	5,814		

[Note] TJJX with larger spray flow and larger flange is available upon request.

## How to order

Please inquire or order for a specific nozzle using this coding system.

<Example>...4TJJX1500S304

Pipe Conn. Size	TJJX	Spray Capacity Code	Material
4		1500	S304
∅		∅	S316
6		4000	

Related Products

For spraying slurry, wear resistance of nozzles must be considered. For such applications, **TJJX-SiC series** nozzles are available. TJJX-SiC series nozzles are made of highly wear-resistant SiC (silicon nitride bonded silicon carbide). Please inquire with us for details.

Full Cone

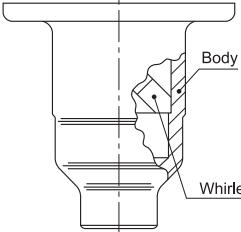
Series	Appearance	Structure	Features	Applications
TJJX-SiC			<ul style="list-style-type: none"> <li>● Full cone spray pattern with a round impact area and uniform distribution.</li> <li>● X-shaped whirler provides large free passage diameter for minimal clogging.</li> <li>● Whole nozzle fired as one piece.</li> <li>● Highly wear-resistant and lightweight structure made of SiC.</li> </ul> <p>[Note] Since TJJX-SiC series nozzles are die-cast molded, the spray capacity is guaranteed within <math>\pm 10\%</math> and the spray angle within <math>\pm 7^\circ</math> under standard pressure.</p>	<ul style="list-style-type: none"> <li>● Spraying recirculated water for water granulation</li> <li>● Other applications for spraying slurry</li> </ul>

# Effective Use of Full Cone Spray Nozzles

## Clogging and Free Passage Diameter

In order to form uniform distribution, full cone spray nozzles are usually fitted with whirlers and this part is the bottleneck of the liquid passage, where clogging problems often occur. Whirlers have several shapes such as X-shaped, disc-shaped and spiral-shaped ones, and the diameter of a sphere that can pass through the whirler is defined as free passage diameter.

As compared with other whirlers, the **X-shaped whirler** has a larger free passage diameter, which minimizes clogging. Some full cone nozzles without whirlers have been developed to eliminate clogging problems, such as the **AJP series** nozzle which features minimal clogging.



X-shaped whirler

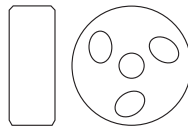

Disc whirler

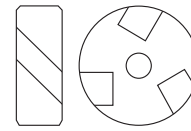

Spiral-shaped whirler

## Wear and Corrosion Resistance

If the liquid contains slurry, the inside of the nozzle exposed to the flow of liquid at high speed will wear out relatively quickly. For these applications, the **JUP series** nozzle is ideal, as the orifice and whirler are made of ceramics. **JUXP, AJP-AL92 and TJJX-SiC series** nozzles are more effective as all parts are made of ceramics. For corrosive applications, nozzles made of special materials such as plastics and titanium alloy are available.

## Mass Savings

For arrangements of many large size nozzles, mass savings of the nozzles affects the total production cost for the systems. The **TJJX series** nozzle with a newly developed X-shaped whirler has a 20% shorter overall length and 20% less mass than conventional nozzles. In addition, the mass of TJJX-SiC series nozzle (made of silicon nitride bonded silicon carbide) is less than half of metal nozzles.

## Rotation Reaction Force

In full cone spray nozzles with whirlers, rotation torque is generated as a reaction force by the vortex current produced by the whirler, which is determined by the following equation.

$$T \approx C \cdot Q \cdot D \cdot \sqrt{P}$$

[Example]

Nozzle No.	Torque at pressure of 0.2 MPa
¾FJJXP23	0.025 N-m
6TJJX4000	3,000 N-m

T: Torque (N-m)

C: Constant

Q: Spray capacity (ℓ/min)

D: External dimension of whirler (mm)

P: Spray pressure (MPa)

## Viscosity

As the viscosity of the liquid increases, generally spray capacity and angle decreases, spray distribution deteriorates and spray droplet size becomes larger.

(Spray capacity of hollow cone spray nozzles increases as the viscosity of liquid increases.

See page 55 for details.)

[Relation between viscosity and spray capacity]

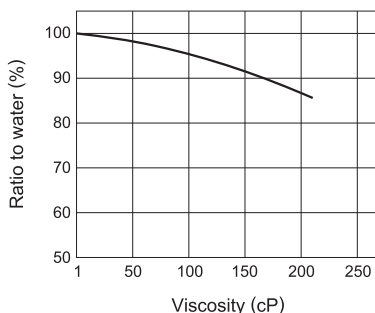

[Relation between viscosity and spray angle]

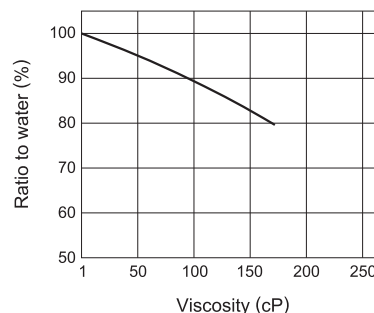

Nozzle tested: JJXP90  
Pressure: 0.02–0.03 MPa

# Wide-angle Full Cone Spray Nozzles

# BBXP/BBXP-PVDF/BBXP-PVC

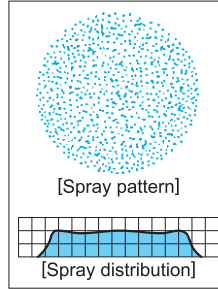

### [Features]

- Wide-angle full cone spray pattern with a round impact area and uniform distribution.
- Spray angle of 120° provides larger spray coverage than other nozzles.
- Spray capacity ranges from small to medium.
- X-shaped whirler provides large free passage diameter for minimal clogging.

### [Standard Pressure]

0.2 MPa for spray capacity codes of 015–060.  
0.35 MPa for spray capacity codes of 10 and over.

### [Applications]

Cleaning: Gas, incinerator fumes, machinery, eliminators, screen, tanks, parts, crushed stones, earth and sand  
Cooling: Gas, machineries, tanks, steel plates  
Spraying: Water treatment, aeration, foam breaking, fire extinguishing, dust suppression, sea water desalination

Full Cone

## BBXP series

BBXP series	
Structure	● One-piece structure with press-fit X-shaped whirler.
Material	<ul style="list-style-type: none"> <li>● Sizes 1/8M–3/8M (3/4F): S303</li> <li>● Sizes 1/2F–1F: S303 or B (brass)</li> <li>● Sizes 1 1/2F or larger: S316</li> <li>● Optional material: S316L or others</li> </ul>

Pipe conn. size*1	Dimensions (mm)						Mass (g)	
	L <sub>1</sub>	L <sub>2</sub>	H	W	φD	N	S303 S316	B
1/8M	21	—	12	—	—	7	11	—
1/4M (015, 020)	21	—	14	—	—	10.5	20	—
1/4M (030)	21.5	—	14	—	—	10.5	20	—
1/4M (040–060)	29	—	14	—	—	10.5	21	—
3/8M	36.5	6	—	17	20	11	55	—
3/8F	45.5	6	—	17	20	11	75	—
1/2F	56	8	—	22	25	14	140	150
3/4F	73	10	—	27	32	15	300	320
1F	94	14	—	34	40	17	585	625
1 1/2F	131	20	—	50	58	19	1,760	—
2F	168	24	—	60	70	23	2,980	—
2 1/2F	199	27	—	80	90	27	5,890	—
3F	220	30	—	90	105	30	9,400	—
4F	278	40	—	115	130	36	16,100	—

\*1) Figures in ( ) after the pipe connection sizes indicate the spray capacity codes.

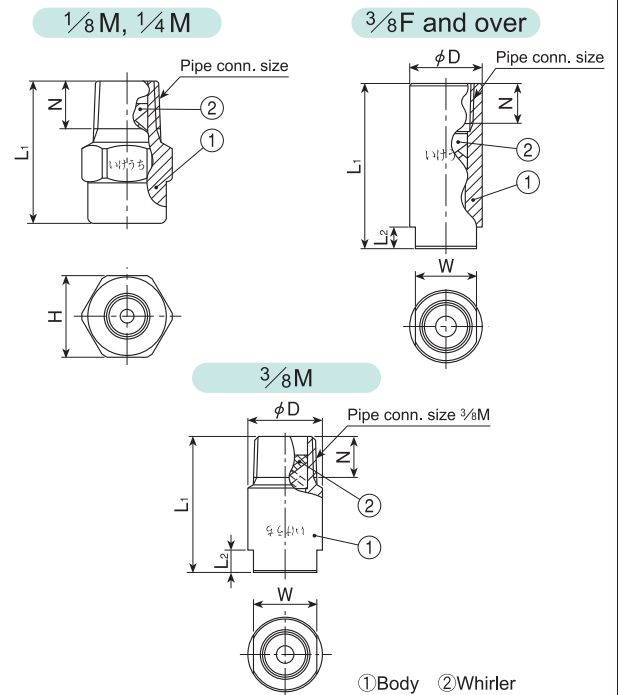

[Note] Appearance and dimensions may differ slightly depending on materials and nozzle codes.

## BBXP-PVDF series

BBXP-PVDF series	
Structure	● One-piece structure with press-fit X-shaped whirler.
Material	● PVDF (polyvinylidene fluoride)

Pipe conn. size	Dimensions (mm)				Mass (g)
	L	H	φD	N	
1/8M	18	12	11	8	2
1/4M	22	14	12	11.5	4.1

[Note] Appearance and dimensions may differ slightly depending on materials and nozzle codes.

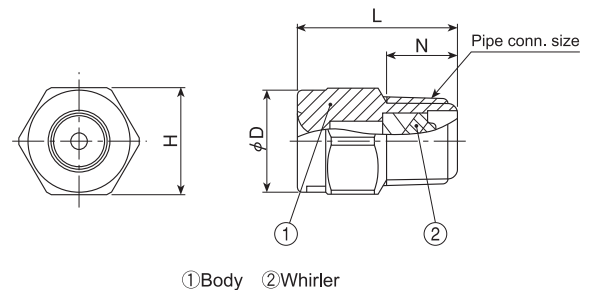

## BBXP-PVC series

BBXP-PVC series	
Structure	● One-piece structure with removable X-shaped whirler.
Material	● PVC (polyvinyl chloride)
Mass	● 1.4 g

[Note] Appearance and dimensions may differ slightly depending on materials and nozzle codes.

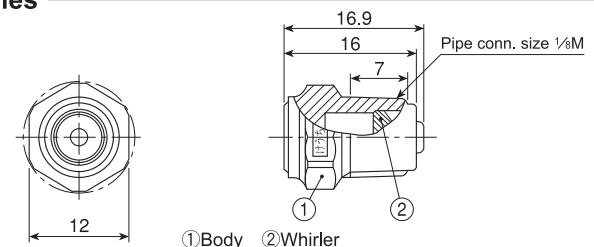

# Wide-angle Full Cone Spray Nozzles

## BBXP/BBXP-PVDF/BBXP-PVC series

Full Cone

### BBXP series

Spray Capacity Code	Pipe Conn. Size		Spray Angle (°)			Spray Capacity (ℓ/min)									Mean Drop. Dia. (μm)	Free Pass. Dia. (mm)
	1/8M	1/4M	0.05 MPa	0.2 MPa	0.5 MPa	0.03 MPa	0.05 MPa	0.1 MPa	0.15 MPa	0.2 MPa	0.35 MPa	0.5 MPa	0.7 MPa	1 MPa		
015	○	○	—	120	112	—	—	1.09	1.32	1.50	1.88	2.18	2.50	2.89	300	0.7
020	○	○	110	120	112	—	1.06	1.46	1.75	2.00	2.51	2.91	3.34	3.86	340	0.9
030	○	○	112	120	113	—	1.59	2.18	2.63	3.00	3.77	4.36	5.00	5.79	340	0.9
040		○	110	120	112	—	2.12	2.91	3.51	4.00	5.03	5.81	6.67	7.72	350	1.4
050		○	112	120	113	—	2.65	3.64	4.38	5.00	6.28	7.27	8.34	9.64	350	1.7
060		○	114	120	114	2.51	3.18	4.37	5.26	6.00	7.54	8.72	10.0	11.6	430	1.7

Spray Capacity Code	Pipe Conn. Size										Spray Angle (°)			Spray Capacity (ℓ/min)									Mean Drop. Dia. (μm)	Free Pass. Dia. (mm)
	3/8M	3/8F	1/2F	3/4F	1F	1 1/2F	2F	2 1/2F	3F	4F	0.15 MPa	0.35 MPa	0.7 MPa	0.03 MPa	0.05 MPa	0.1 MPa	0.15 MPa	0.2 MPa	0.35 MPa	0.5 MPa	0.7 MPa	1 MPa		
10	○	○									123	120	111	3.34	4.21	5.79	6.98	7.96	10.0	11.6	13.3	15.3	340	2.0
12	○	○									124	120	112	4.00	5.06	6.95	8.37	9.55	12.0	13.9	15.9	18.4	340	2.0
14	○	○									124	120	112	4.67	5.90	8.10	9.77	11.1	14.0	16.2	18.6	21.5	340	2.4
16	○	○									125	120	113	5.33	6.74	9.25	11.2	12.7	16.0	18.5	21.2	24.6	340	2.6
18			○								123	120	111	6.00	7.58	10.4	12.6	14.3	18.0	20.8	23.9	27.6	420	2.8
20			○								123	120	111	6.67	8.43	11.6	14.0	15.9	20.0	23.1	26.5	30.7	420	2.8
23			○								124	120	112	7.67	9.69	13.3	16.0	18.3	23.0	26.6	30.5	35.3	420	2.8
26			○								124	120	112	8.67	11.0	15.1	18.1	20.7	26.0	30.1	34.5	39.9	480	2.8
30				○							123	120	111	10.0	12.6	17.4	20.9	23.9	30.0	34.7	39.8	46.0	580	3.8
40				○							124	120	112	13.3	16.9	23.2	27.9	31.8	40.0	46.3	53.1	61.4	580	4.8
50				○							125	120	113	16.7	21.0	29.0	34.9	39.8	50.0	57.8	66.3	76.7	580	4.8
60					○						124	120	112	20.0	25.3	34.7	41.9	47.7	60.0	69.4	79.6	92.1	630	5.4
80					○						125	120	113	26.7	33.7	46.3	55.8	63.7	80.0	92.5	106	123	630	6.0
100						○					123	120	111	33.3	42.1	57.9	69.8	79.6	100	115	135	155	710	7.2
150						○					124	120	112	50.0	63.2	86.9	105	120	150	175	200	230	900	8.5
200							○				124	120	112	66.7	84.3	115	140	160	200	230	265	310	710	8.9
300							○				125	120	113	100	125	175	210	240	300	350	400	460	900	10.2
400								○			124	120	112	135	170	235	280	320	400	465	530	615	900	14.3
500								○			125	120	113	170	210	290	350	400	500	580	665	770	1,000	14.3
600									○		124	120	112	200	255	350	420	480	600	695	795	920	1,100	19.0
700									○		125	120	113	235	295	405	490	550	700	810	930	1,070	1,100	19.0
900										○	124	120	112	300	380	520	630	720	900	1,041	1,195	1,380	1,200	19.8
1200										○	125	120	113	400	505	695	840	955	1,200	1,390	1,590	1,840	1,200	21.7

### BBXP-PVDF series

Spray Capacity Code	Pipe Conn. Size		Spray Angle (°)			Spray Capacity (ℓ/min)									Mean Drop. Dia. (μm)	Free Pass. Dia. (mm)	Nozzle Body Color
	1/8M	1/4M	0.05 MPa	0.2 MPa	0.5 MPa	0.03 MPa	0.05 MPa	0.1 MPa	0.15 MPa	0.2 MPa	0.35 MPa	0.5 MPa	0.7 MPa	1 MPa			
008	○		—	120	112	—	—	0.58	0.70	0.80	1.00	1.16	1.33	1.54	280	0.5	Black
015	○	○	—	120	112	—	—	1.09	1.32	1.50	1.88	2.18	2.50	2.89	340	0.8	Gray
020	○	○	110	120	113	—	1.06	1.46	1.75	2.00	2.51	2.91	3.34	3.86	340	1.2	Black

\*Nozzle body colors differ depending on Spray Capacity Codes; BBXP008 and BBXP020 are black (BLA), BBXP015 is gray (GRA).

### BBXP-PVC series

Spray Angle (°)			Spray Capacity (ℓ/min)									Mean Drop. Dia. (μm)	Free Pass. Dia. (mm)
0.05 MPa	0.2 MPa	0.5 MPa	0.03 MPa	0.05 MPa	0.1 MPa	0.15 MPa	0.2 MPa	0.3 MPa	0.5 MPa	0.7 MPa	1 MPa		
115	120	110	—	1.59	2.18	2.63	3.00	3.54	4.36	5.00	5.79	350	1.5

### How to order

Please inquire or order for a specific nozzle using this coding system.

#### ① BBXP series (metal)

(Example) ...1/8M BBXP015S303

1/8M	BBXP	015	S303
Pipe Conn. Size(*1)		Spray Capacity Code	Material(*2)
1/8M		015	S303
4F		1200	S316

#### ② BBXP-PVDF series

(Example) ...1/8M BBXP020PVDF (BLA)

1/8M	BBXP	020	PVDF	(BLA)
Pipe Conn. Size		Spray Capacity Code		Nozzle Color
1/8M		008		BLA (BBXP008, 020)
1/4x1/8M(*3)		015		GRA (BBXP015)
		020		

#### ③ BBXP-PVC series

1/8M BBXP030PVC-IN

\*1) When Spray Capacity Code is 015–030, Pipe Connection Size for 1/4M is indicated as "1/4x1/8M".

\*2) See "Material" information on page 72 for standard materials by each size.

\*3) Pipe Connection Size code for 1/4M is "1/4x1/8M" in BBXP-PVDF series.



# Effective Use of Full Cone Spray Nozzles

## Clogging and Free Passage Diameter

In order to form uniform distribution, full cone spray nozzles are usually fitted with whirlers and this part is the bottleneck of the liquid passage, where clogging problems often occur. Whirlers have several shapes such as X-shaped, disc-shaped and spiral-shaped ones, and the diameter of a sphere that can pass through the whirler is defined as free passage diameter.

As compared with other whirlers, the **X-shaped whirler** has a larger free passage diameter, which minimizes clogging. Some full cone nozzles without whirlers have been developed to eliminate clogging problems, such as the **AJP series** nozzle which features minimal clogging.



X-shaped whirler

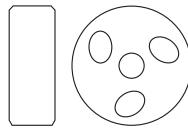

Disc whirler

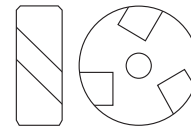

Spiral-shaped whirler

## Wear and Corrosion Resistance

If the liquid contains slurry, the inside of the nozzle exposed to the flow of liquid at high speed will wear out relatively quickly. For these applications, the **JUP series** nozzle is ideal, as the orifice and whirler are made of ceramics. **JUXP, AJP-AL92 and TJJX-SiC series** nozzles are more effective as all parts are made of ceramics. For corrosive applications, nozzles made of special materials such as plastics and titanium alloy are available.

## Mass Savings

For arrangements of many large size nozzles, mass savings of the nozzles affects the total production cost for the systems. The **TJJX series** nozzle with a newly developed X-shaped whirler has a 20% shorter overall length and 20% less mass than conventional nozzles. In addition, the mass of TJJX-SiC series nozzle (made of silicon nitride bonded silicon carbide) is less than half of metal nozzles.

## Rotation Reaction Force

In full cone spray nozzles with whirlers, rotation torque is generated as a reaction force by the vortex current produced by the whirler, which is determined by the following equation.

$$T \approx C \cdot Q \cdot D \cdot \sqrt{P}$$

[Example]

Nozzle No.	Torque at pressure of 0.2 MPa
¾FJJXP23	0.025 N-m
6TJJX4000	3,000 N-m

T: Torque (N-m)

C: Constant

Q: Spray capacity (ℓ/min)

D: External dimension of whirler (mm)

P: Spray pressure (MPa)

## Viscosity

As the viscosity of the liquid increases, generally spray capacity and angle decreases, spray distribution deteriorates and spray droplet size becomes larger.

(Spray capacity of hollow cone spray nozzles increases as the viscosity of liquid increases.

See page 55 for details.)

[Relation between viscosity and spray capacity]

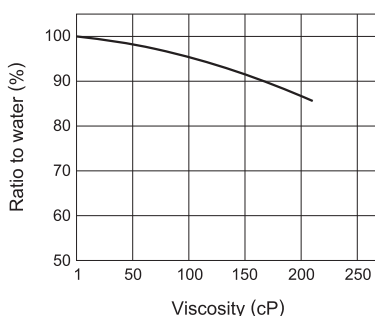

[Relation between viscosity and spray angle]

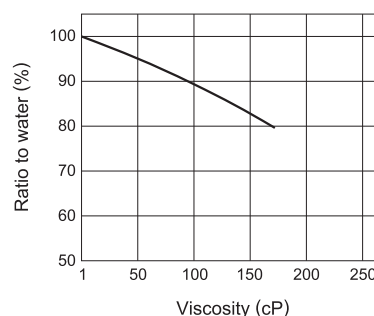

Nozzle tested: JJXP90  
Pressure: 0.02–0.03 MPa

# Narrow-angle Full Cone Spray Nozzles

# NJJP

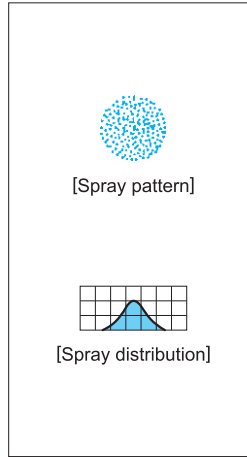

### [Features]

- Narrow-angle full cone spray pattern with a round impact area and uniform distribution.
- Unique design producing fine atomization without a whirler.
- No-whirler design with large free passage diameter minimizes clogging.

### [Standard Pressure]

0.3 MPa

### [Applications]

Cleaning: Pipes, bottles, containers, filters  
Cooling: Steel plates

Full Cone

## NJJP series

NJJP series	
Structure	<ul style="list-style-type: none"> <li>• One piece structure with press-fit orifice tip.</li> <li>• No obstructions in nozzle interior.</li> </ul>
Material	<ul style="list-style-type: none"> <li>• S303</li> <li>• Optional material: S316</li> </ul>

Pipe conn. size	Dimensions (mm)				Mass (g)
	L	H	φD	N	
1/4M	24	14	13.5	10.5	19.5
3/8M	32	19	18	11	48

[Note] Appearance and dimensions may differ slightly depending on materials and nozzle codes.

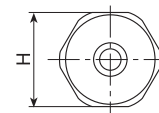
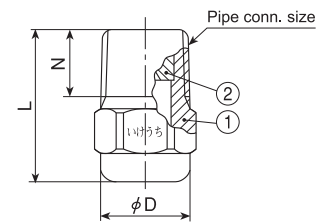

①Body ②Orifice tip

Spray Angle Code	Spray Capacity Code	Pipe Conn. Size		Spray Angle (°)			Spray Capacity (ℓ/min)						Mean Drop. Dia. (μm)	Free Pass. Dia. (mm)
		1/4M	3/8M	0.15 MPa	0.3 MPa	0.7 MPa	0.15 MPa	0.2 MPa	0.3 MPa	0.5 MPa	0.7 MPa	1 MPa		
30	06	○		26	30	32	4.80	5.26	6.00	7.42	8.54	9.91	750	2.5
	08	○		26	30	32	6.40	7.02	8.00	9.90	11.4	13.2		
	14		○	26	30	32	11.2	12.3	14.0	17.3	19.9	23.1		
	20		○	26	30	32	16.0	17.5	20.0	24.7	28.5	33.0		
15	06	○		12	15	16	4.80	5.26	6.00	7.42	8.54	9.91	925	2.4
	08	○		12	15	16	6.40	7.02	8.00	9.90	11.4	13.2		
	14		○	12	15	16	11.2	12.3	14.0	17.3	19.9	23.1		
	20		○	12	15	16	16.0	17.5	20.0	24.7	28.5	33.0		

### Precautions for use

Please use NJJP series nozzles at water pressure of 0.15 MPa or greater to obtain a stable spray pattern.

### How to order

Please inquire or order for a specific nozzle using this coding system.

〈Example〉...1/4MNJJP3006S303

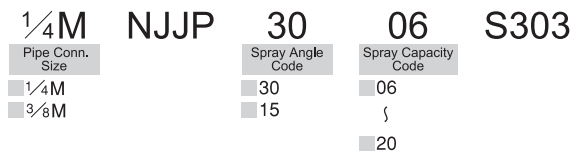

# Clog-resistant Vaneless Full Cone Spray Nozzles

## AJP/AJP-PPS

Full Cone

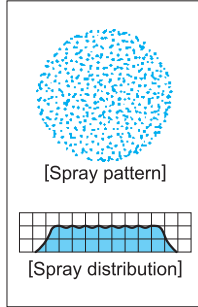
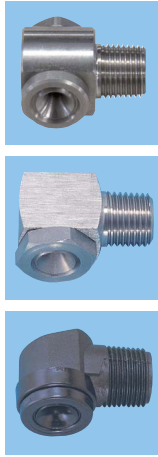

### [Features]

- Full cone spray pattern with a round impact area and uniform distribution.
- Unique design to produce fine atomization by liquid impinging inside chamber without a whirler.
- No-whirler design with large free passage diameter minimizes clogging.
- Spraying axis 90° from the axis of the nozzle inlet.
- For spraying chemicals such as hydrochloric acid, PPS-injection molded AJP are available for excellent chemical and heat resistance.

### [Standard Pressure]

0.2 MPa

### [Applications]

Cleaning: Pre-painting treatment, washing booths, machine parts, gas, incinerator fumes  
 Cooling: Steel plates, copper pieces, gas  
 Spraying: Aeration, foam breaking  
 Others: Applications where re-circulated water is being used or clogging is a concern

## AJP series

AJP series	
Structure	<ul style="list-style-type: none"> <li>• Comprises nozzle body and orifice cap</li> <li>• Only 1/8M size comprises nozzle body, orifice cap, and plug.</li> <li>• Orifice cap of sizes 3/8M and 1/2M are pressed into bodies.</li> <li>• No obstructions in nozzle interior.</li> </ul>
Material	<ul style="list-style-type: none"> <li>• Body: S304 or S303 or SCS13 (vary by nozzle code)</li> <li>• Orifice cap: S303</li> <li>• Optional material: S316</li> </ul>

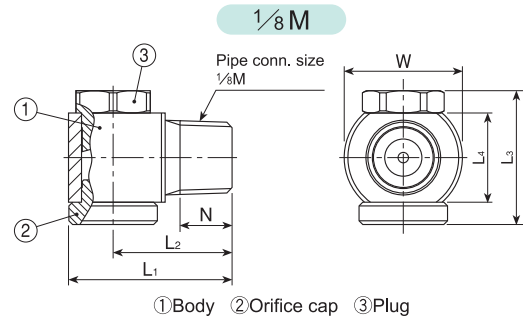

Pipe conn. size	Dimensions (mm)						Mass (g)
	L <sub>1</sub>	L <sub>2</sub>	L <sub>3</sub>	L <sub>4</sub>	W	N	
1/8M	22	16	18	12	15.9	7	23
1/4M	32	23	20.5	16	16	10.5	55
3/8M	36	26	23.5	19	20	11	70
1/2M	46	33.5	31	25	25	14	180
3/4M	55	39	38	32	32	15	340
1M	70	50	48	40	40	18	670
1 1/2M	100	70	72	58.5	58.5	20	2,400

[Note] Appearance and dimensions may differ slightly depending on materials and nozzle codes.

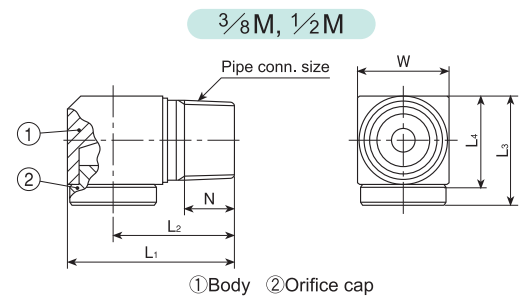
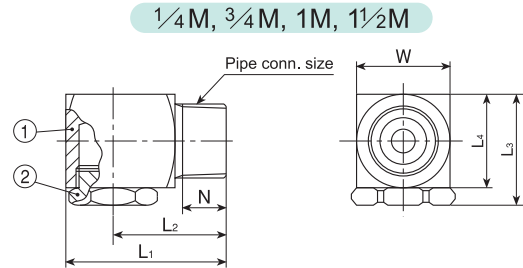

## AJP-PPS series

AJP-PPS series	
Structure	<ul style="list-style-type: none"> <li>• One-piece structure with orifice cap electrodeposited to the body.</li> <li>• No obstructions in nozzle interior.</li> </ul>
Material	• PPS (polyphenylene sulfide)

Pipe conn. size	Dimensions (mm)						Mass (g)
	L <sub>1</sub>	L <sub>2</sub>	L <sub>3</sub>	L <sub>4</sub>	W	N	
1/4M	32.5	23	20.5	17	16	10.5	6.8
3/8M	37	26	23	20	19	11	10.3

[Note] Appearance and dimensions may differ slightly depending on materials and nozzle codes.

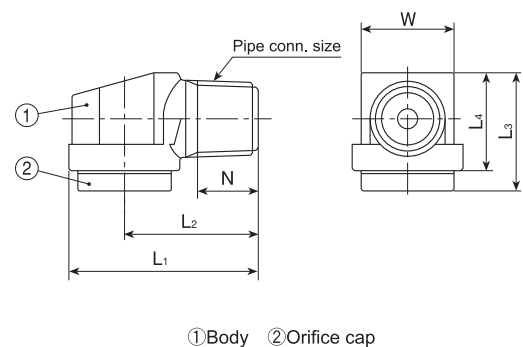

## Clog-resistant, Vaneless Full Cone Spray Nozzles AJP/AJP-PPS series

Spray Capacity Code	AJP (Metal)							AJP-PPS (Plastic)		Spray Angle (°)			Spray Capacity (ℓ/min)						Mean Drop. Dia. (μm)	Free Pass. Dia. (mm)	
	1/8M	1/4M	3/8M	1/2M	3/4M	1M	1 1/2M	1/4M	3/8M	0.05 MPa	0.2 MPa	0.5 MPa	0.03 MPa	0.05 MPa	0.1 MPa	0.15 MPa	0.2 MPa	0.3 MPa			0.5 MPa
02	○									64	75	69	—	1.02	1.43	1.74	2.00	2.35	2.89	640	1.6
03	○									65	75	69	—	1.53	2.14	2.61	3.00	3.53	4.33		1.9
04		○								65	75	68	1.59	2.04	2.86	3.48	4.00	4.70	5.77	}	2.2
05		○								65	75	68	1.99	2.55	3.57	4.35	5.00	5.88	7.21		2.5
06		○								70	80	73	2.39	3.06	4.29	5.22	6.00	7.06	8.66		2.8
07		○								70	80	73	2.79	3.57	5.00	6.09	7.00	8.23	10.1		3.1
08			○							70	80	73	3.19	4.08	5.71	6.96	8.00	9.54	11.9		740
10			○							70	80	73	3.98	5.10	7.14	8.70	10.0	11.9	14.9	}	3.7
12			○							75	85	78	4.78	6.12	8.57	10.4	12.0	14.3	17.9		4.1
14			○							75	85	78	5.57	7.14	10.0	12.2	14.0	16.7	20.9		4.5
16			○							75	85	78	6.37	8.16	11.4	13.9	16.0	19.1	23.8	820	5.0
18				○						76	85	79	7.17	9.18	12.9	15.7	18.0	21.6	27.1	}	5.1
20				○						76	85	79	7.96	10.2	14.3	17.4	20.0	23.9	30.1		5.4
23				○						76	85	79	9.16	11.7	16.4	20.0	23.0	27.5	34.6		6.0
26				○						76	85	79	10.4	13.3	18.6	22.6	26.0	31.1	39.1		6.5
30				○						76	85	79	11.9	15.3	21.4	26.1	30.0	35.9	45.1		900
35				○						83	90	85	13.9	17.9	25.0	30.4	35.0	41.9	52.6	}	7.8
40				○						83	90	85	15.9	20.4	28.6	34.8	40.0	47.9	60.1		8.5
45				○						83	90	85	17.9	23.0	32.1	39.1	45.0	53.9	67.6		9.2
50				○						83	90	85	19.9	25.5	35.7	43.5	50.0	59.9	75.1	9.8	
55					○					83	90	85	21.9	28.1	39.3	47.8	55.0	65.9	82.6	1,000	9.6
60					○					83	90	85	23.9	30.6	42.9	52.2	60.0	71.8	90.2	}	10.1
70					○					83	90	85	27.9	35.7	50.0	60.9	70.0	83.8	105		11.2
80					○					83	90	85	31.9	40.8	57.1	69.6	80.0	95.8	120		12.2
90					○					83	90	85	35.8	45.9	64.3	78.3	90.0	108	135	13.0	
100						○				83	90	85	39.8	51.0	71.4	87.0	100	120	150	1,120	13.0
120						○				83	90	85	47.8	61.2	85.7	104	120	144	180	}	14.8
150						○				83	90	85	59.7	76.5	107	130	150	180	225		17.4
180							○			83	90	85	71.7	91.8	129	157	180	216	270	1,280	17.8
200							○			83	90	85	79.6	102	143	174	200	239	301	1,350	18.8
250							○			83	90	85	99.5	128	179	217	250	299	376	1,350	22.3

Full Cone

### How to order

Please inquire or order for a specific nozzle using this coding system.

#### ① AJP series (Metal)

〈Example〉...1/4MAJP04S303

1/4M	AJP	04	S303
Pipe Conn. Size		Spray Capacity Code	
■ 1/8M		■ 02	
}		}	
■ 1 1/2M		■ 250	

#### ② AJP-PPS series (Plastic)

〈Example〉...3/8MAJP08PPS

3/8M	AJP	08	PPS
Pipe Conn. Size		Spray Capacity Code	
■ 1/4M		■ 04	
■ 3/8M		}	
		■ 16	

# Clog-resistant Vaneless Full Cone Spray Nozzles

## AJP-AL92

### Related Products

Clog-resistant full cone nozzle made of highly wear-resistant and chemical-resistant alumina ceramics.

Full Cone

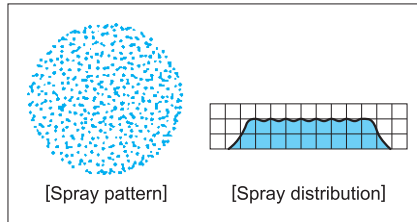

#### [Features]

- Full cone spray pattern with a round impact area and uniform distribution.
- Unique design to produce fine atomization by liquid impinging inside chamber without a whirler.
- No-whirler design with large free passage diameter minimizes clogging.
- Spraying axis 90° from the axis of the nozzle inlet.
- Right angle nozzle suitable for installation in narrow space.

#### [Standard Pressure]

0.2 MPa

#### [Applications]

- Spraying slurry
- Absorption tower of flue gas desulfurization equipment
- Spraying water in cooling tower

### AJP-AL92 series

AJP-AL92 series	
Structure	<ul style="list-style-type: none"> <li>• Whole nozzle fired as one piece.</li> <li>• No obstructions in nozzle interior.</li> </ul>
Material	<ul style="list-style-type: none"> <li>• 92% Alumina</li> </ul>

\* If installed into a metal header, this nozzle should be used with a socket made of S316, shown on page 85 (otherwise, the thread may be damaged). Please refer to page 85.

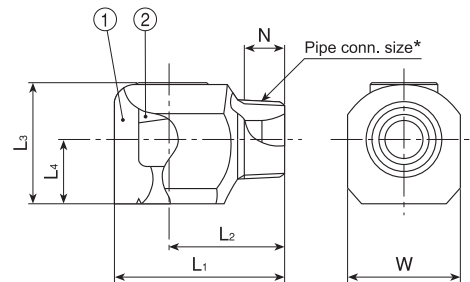

①Ceramic body ②Ceramic plate

Pipe conn. size*	Dimensions (mm)						Mass (g)
	L <sub>1</sub>	L <sub>2</sub>	L <sub>3</sub>	L <sub>4</sub>	W	N	
1/2M	49.5	33.5	36	18	32	14	120
3/4M	59	39	44	22	41	15	220
1M	76	50	54	28	50	18	450
1 1/2M	106	70	80.5	43.5	75	20	1,600

\* When used with our S316 socket, socket thread for pipe connection is female thread.  
Drawing for nozzle with socket is available on request.  
(The above drawing is nozzle only)

[Note] Appearance and dimensions may differ slightly depending on materials and nozzle codes.

# Clog-resistant, Vaneless Full Cone Spray Nozzles AJP-AL92 series

Spray Capacity Code	Pipe Conn. Size				Spray Angle (°)			Spray Capacity (ℓ/min)							Mean Drop. Dia. (μm)	Free Pass. Dia. (mm)
	1/2M	3/4M	1M	1 1/2M	0.05 MPa	0.2 MPa	0.5 MPa	0.03 MPa	0.05 MPa	0.1 MPa	0.15 MPa	0.2 MPa	0.3 MPa	0.5 MPa		
18	○				76	85	79	7.16	9.18	12.9	15.7	18.0	21.5	27.1	800	5.1
20	○				76	85	79	7.96	10.2	14.3	17.4	20.0	23.9	30.1		5.4
23	○				76	85	79	9.15	11.7	16.4	20.0	23.0	27.5	34.6		6.0
26	○				76	85	79	10.3	13.3	18.6	22.6	26.0	31.1	39.1		6.5
30	○				76	85	79	11.9	15.3	21.4	26.1	30.0	35.9	45.1		7.1
35	○				83	90	85	13.9	17.9	25.0	30.5	35.0	41.9	52.6		7.8
40	○				83	90	85	15.9	20.4	28.6	34.8	40.0	47.9	60.1	}	8.5
45	○				83	90	85	17.9	23.0	32.1	39.2	45.0	53.9	67.6		9.2
50	○				83	90	85	19.9	25.5	35.7	43.5	50.0	59.9	75.2		9.8
55		○			83	90	85	21.9	28.1	39.3	47.9	55.0	65.8	82.7		9.6
60		○			83	90	85	23.9	30.6	42.8	52.2	60.0	71.8	90.2		10.1
70		○			83	90	85	27.9	35.7	50.0	60.9	70.0	83.8	105		11.2
80		○			83	90	85	31.4	40.8	57.1	69.6	80.0	95.8	120		12.2
90		○			83	90	85	35.8	45.9	64.3	78.3	90.0	108	135	1,250	13.0
100			○		83	90	85	39.8	51.0	71.4	87.0	100	120	150		
120			○		83	90	85	47.8	61.2	85.7	104	120	144	180		14.8
150			○		83	90	85	59.7	76.5	107	131	150	180	226	}	17.4
180				○	83	90	85	71.6	91.8	129	157	180	216	271		
200				○	83	90	85	79.6	102	143	174	200	240	300		18.8
250				○	83	90	85	99.5	128	179	217	250	299	376	1,400	22.3

Full Cone

## How to order

Please inquire or order for a specific nozzle using this coding system.

〈Example〉...1/2MAJP18 AL92

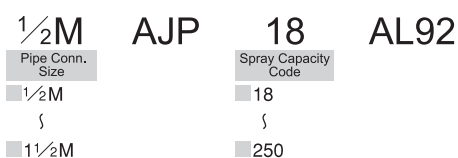

# Effective Use of Full Cone Spray Nozzles

## Clogging and Free Passage Diameter

In order to form uniform distribution, full cone spray nozzles are usually fitted with whirlers and this part is the bottleneck of the liquid passage, where clogging problems often occur. Whirlers have several shapes such as X-shaped, disc-shaped and spiral-shaped ones, and the diameter of a sphere that can pass through the whirler is defined as free passage diameter.

As compared with other whirlers, the **X-shaped whirler** has a larger free passage diameter, which minimizes clogging. Some full cone nozzles without whirlers have been developed to eliminate clogging problems, such as the **AJP series** nozzle which features minimal clogging.



X-shaped whirler

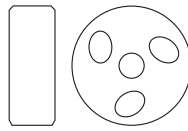

Disc whirler

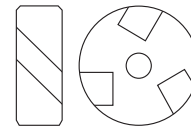

Spiral-shaped whirler

## Wear and Corrosion Resistance

If the liquid contains slurry, the inside of the nozzle exposed to the flow of liquid at high speed will wear out relatively quickly. For these applications, the **JUP series** nozzle is ideal, as the orifice and whirler are made of ceramics. **JUXP, AJP-AL92 and TJJX-SiC series** nozzles are more effective as all parts are made of ceramics. For corrosive applications, nozzles made of special materials such as plastics and titanium alloy are available.

## Mass Savings

For arrangements of many large size nozzles, mass savings of the nozzles affects the total production cost for the systems. The **TJJX series** nozzle with a newly developed X-shaped whirler has a 20% shorter overall length and 20% less mass than conventional nozzles. In addition, the mass of TJJX-SiC series nozzle (made of silicon nitride bonded silicon carbide) is less than half of metal nozzles.

## Rotation Reaction Force

In full cone spray nozzles with whirlers, rotation torque is generated as a reaction force by the vortex current produced by the whirler, which is determined by the following equation.

$$T \approx C \cdot Q \cdot D \cdot \sqrt{P}$$

[Example]

Nozzle No.	Torque at pressure of 0.2 MPa
¾FJJXP23	0.025 N-m
6TJJX4000	3,000 N-m

T: Torque (N-m)

C: Constant

Q: Spray capacity (ℓ/min)

D: External dimension of whirler (mm)

P: Spray pressure (MPa)

## Viscosity

As the viscosity of the liquid increases, generally spray capacity and angle decreases, spray distribution deteriorates and spray droplet size becomes larger.

(Spray capacity of hollow cone spray nozzles increases as the viscosity of liquid increases.

See page 55 for details.)

[Relation between viscosity and spray capacity]

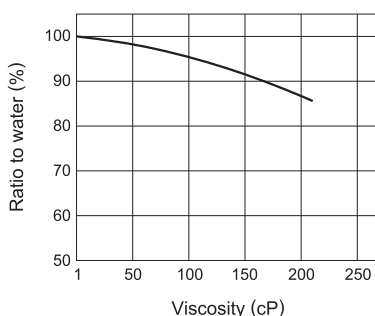

[Relation between viscosity and spray angle]

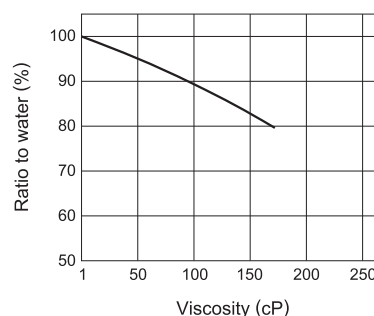

Nozzle tested: JJXP90  
Pressure: 0.02–0.03 MPa

7-head Full Cone Spray Nozzles / Standard type  
**7JJXP series**

Related Products

13JJXP series (13-head Full Cone Spray Nozzles)

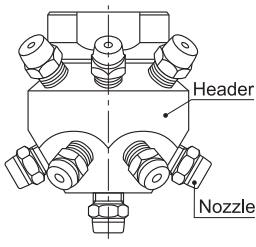
Series	Appearance	Structure	Features	Applications
13JJXP			<ul style="list-style-type: none"> <li>• Full cone spray pattern with uniform spray distribution.</li> <li>• 13 pcs. of JJXP series full cone spray nozzles are screwed into a very compact header.</li> <li>• Spray droplet diameter is smaller than those of other single-head full cone spray nozzles having the same spray capacity.</li> </ul>	<ul style="list-style-type: none"> <li>• Gas cooling</li> <li>• Moisture control</li> </ul>

Socket for Alumina Nozzles

Optional socket available for alumina nozzles (AP-AL92, JUXP-AL92, AJP-AL92 series).

Material of socket: S316

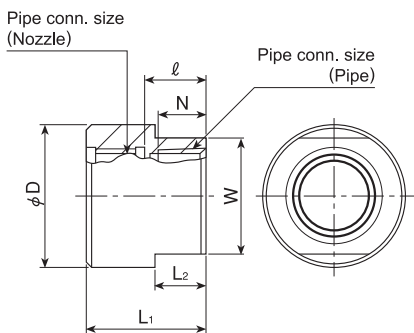

Nominal diameter	Pipe conn. size		Dimensions (mm)						Mass (g)
	Nozzle	Pipe	L <sub>1</sub>	L <sub>2</sub>	ℓ	W	φD	N	
1/2	1/2	1/2	34	10	18	27	30	14	120
3/4	3/4	3/4	39	14	21	35	40	15	230
3/4x1	1	3/4	41	18	21	41	50	15	200
1	1	1	43	18	23	41	50	17	400
1x1 1/2	1 1/2	1	47	24	24	60	70	17	560
1 1/2	1 1/2	1 1/2	50	24	27	60	70	19	840
1 1/2x2	2	1 1/2	54	27	27	70	80	19	680
2	2	2	58	27	31	70	80	23	1,100
2x2 1/2	2 1/2	2	62	30	31	90	100	23	1,400
2 1/2	2 1/2	2 1/2	66	30	35	90	100	27	2,000
2 1/2x3	3	2 1/2	71	35	36	100	110	27	1,500
3	3	3	75	35	40	100	110	30	2,200

\* Thread for connecting pipe is female taper thread.



# Quick-Detachable High-efficiency Etching Nozzles

# SNAPJet

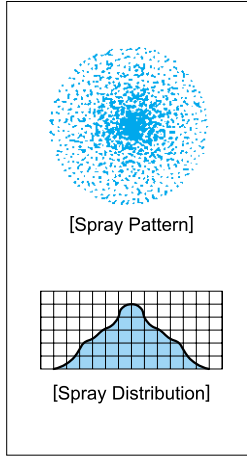

### [Features]

- Mountain-shaped distribution and high spray impact achieve high-precision etching.
- Uniform etching effect in any production lines because the distortion of spray distribution is minimized even if spray pressure is modulated.
- Quick-detachable design makes periodic maintenance easy.
- Whirler inside the nozzles is also removable.
- Also available in titanium for high-temperature and high-pressure condition.

### [Standard Pressure]

0.2MPa

### [Applications]

Shadow mask etching, lead frame etching  
High-precision etching for PCB and TAB, etc.

Full Cone

## SNAPJet-series

SNAPJet-series	
Structure	<ul style="list-style-type: none"> <li>• 2-piece structure comprised of adaptor and nozzle with whirler.</li> <li>• Nozzle is removable only by turning 90°.</li> </ul>
Material	<ul style="list-style-type: none"> <li>• Nozzle body, adaptor and whirler : PPS(polyphenylene sulfide)</li> <li>• Packing : EPDM</li> <li>• Optional material : Nozzle body made of TN (titanium)</li> </ul>

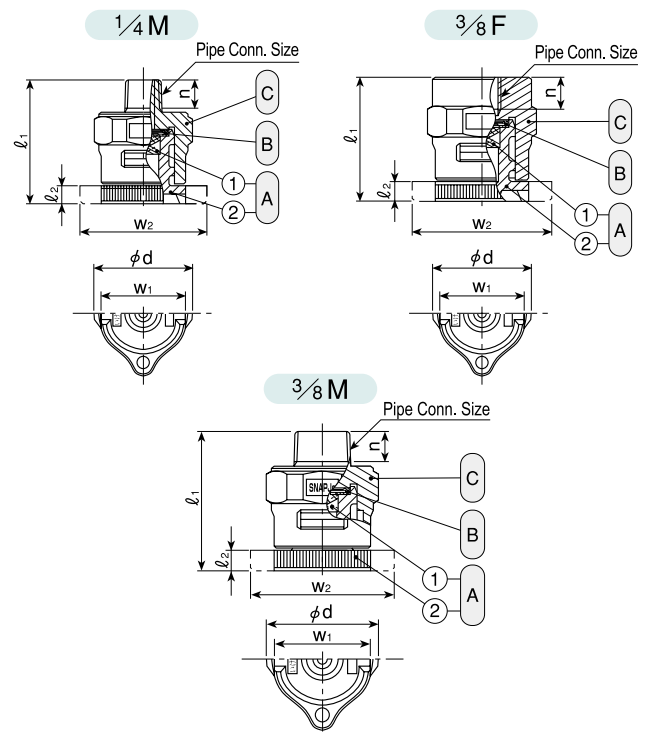

Series	Pipe Conn. Size	Dimensions(mm)						Mass (g)
		$l_1$	$l_2$	$\phi d$	$w_1$	$w_2$	$n$	
SNAPJet	1/4 M	44	6.5	35	30	45	10	30
	3/8 F	44	6.5	35	30	45	11	40
	3/8 M	44	6.5	35	30	45	10	35

[Note] Appearance and dimensions may differ slightly depending on materials and nozzle codes.

Ⓐ Nozzle (Ⓛ Whirler Ⓜ Body) ⓑ Packing-EPDM ⓒ Adaptor-PPS

Spray Capacity Code	Pipe Conn. Size (Adaptor)		Spray Angle			Spray Capacity (ℓ/min)							Mean Drop. Dia. (μm)	Free Pass. Dia. (mm)
	1/4 M	3/8 F	0.05 MPa	0.2 MPa	0.5 MPa	0.05 MPa	0.1 MPa	0.15 MPa	0.2 MPa	0.3 MPa	0.5 MPa	0.7 MPa		
040	○	○	54°	65°	64°	2.10	2.90	3.50	4.00	4.79	6.01	6.98	380	1.6
050	○	○	54°	65°	64°	2.62	3.62	4.37	5.00	5.99	7.51	8.73		
060	○	○	59°	70°	69°	3.15	4.35	5.25	6.00	7.18	9.02	10.5		
070	○	○	64°	75°	74°	3.67	5.07	6.12	7.00	8.38	10.5	12.2		

### How to order

Please inquire or order for a specific nozzle using this coding system.

#### ① Complete unit

<Example>...1/4MSNAPJJX040PPS+PPS

1/4 M	SNAPJJX	040	PPS+PPS
Pipe Conn. Size		Spray Capacity Code	
1/4 M		040	
3/8 F		∅	
3/8 M		070	

#### ② Nozzle only

<Example>...SNAPJJX040PPS

SNAPJJX	040	PPS
	Spray Capacity Code	
	040	
	∅	
	070	

# For Effective Use of Full Cone Spray Nozzles

## Clogging & Free Passage Diameter

In order to form uniform distribution, full cone spray nozzles are usually fitted with whirlers and this part is the bottleneck of the liquid passage, where clogging problems often occur. Whirlers have several shapes such as X-shaped, disc-shaped and spiral-shaped ones, and the diameter of a sphere that can pass through the whirler is defined as free passage diameter.

As compared with other whirlers, the **X-shaped whirler** has a larger free passage diameter, which minimizes clogging. Some full cone nozzles without whirlers have been developed to eliminate clogging problems, such as the **AJP-series** which features minimal clogging.

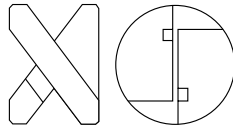

X-shaped whirler

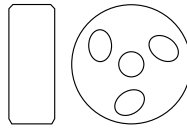

Disc whirler

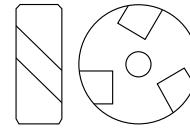

Spiral-shaped whirler

## Wear and Corrosion Resistance

If the liquid contains slurry, the inside of the nozzle exposed to the flow of liquid at high speed will wear out relatively quickly. For these applications, the **JUP-series** is ideal, as the orifice and whirler are made of ceramics. **JUXP, AJP-AL92 and TJJX-SiC series** are more effective as all parts are made of ceramics. For corrosive applications, nozzles made of special materials such as plastics and titanium alloy are available.

## Weight Savings

For arrangements of many large size nozzles, weight savings of the nozzles affects the total production cost for the systems. The **TJJX-series** with a newly developed X-shaped whirler has a 20% shorter overall length and 20% less weight than conventional nozzles. In addition, the weight of TJJX-SiC is less than half of metal nozzles.

## Rotation Reaction Force

In full cone spray nozzles with whirlers, rotation torque is generated as a reaction force by the vortex current produced by the whirler, which is determined by the following equation.

$$T \cong C \cdot Q \cdot D \cdot \sqrt{P}$$

[ Example ]

Nozzle No.	Torque at pressure of 0.2MPa
¾FJJXP23	2.5N-cm
8TJJX8000	8,000N-cm

T : Torque (N-cm)

C : Constant

Q : Spray capacity (ℓ/min)

D : External dimension of whirler (mm)

P : Spray pressure (MPa)

## Viscosity

As the viscosity of the liquid increases, generally spray capacity and angle decreases, spray distribution deteriorates and spray droplet size becomes larger.

(Spray capacity of hollow cone spray nozzles increases as the viscosity of liquid increases. See p.55 for details.)

[ Relation between viscosity and spray capacity ]

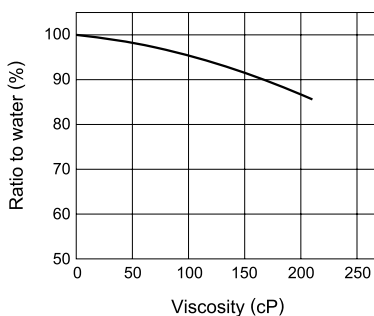

[ Relation between viscosity and spray angle ]

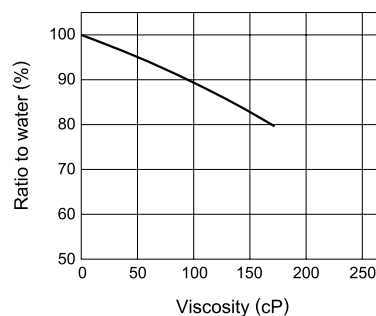

Nozzle tested : JJXP90  
Pressure : 0.02-0.03MPa

# Square Spray Nozzles

# SSXP / SSXP-HTPVC

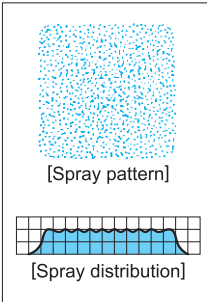

### [Features]

- Square full cone spray pattern with uniform distribution.
- Wide spray angle of 90–100° provides large spray coverage.
- Square full cone spray pattern leaves no gaps in multiple-nozzle arrangements.
- X-shaped whirler provides large free passage diameter for minimal clogging.

### [Standard Pressure]

SSXP series: 0.2 MPa  
SSXP-HTPVC series: 0.15 MPa

### [Applications]

Cleaning: Gas, incinerator fumes, machinery, eliminators, screen, tanks, crushed stones, earth and sand  
Cooling: Gas, machinery, tanks, steels  
Spraying: Waste water treatment, foam breaking, fire extinguishing, dust suppression

## SSXP series

SSXP series	
Structure	● One-piece structure with press-fit X-shaped whirler.
Material	<ul style="list-style-type: none"> <li>● Sizes 1F or smaller: S303 or B (brass)</li> <li>● Sizes 1½F or larger: S316 (SCS14)</li> <li>● Optional material: S316L (SCS16)</li> </ul>

Pipe conn. size	Dimensions (mm)							Mass (g)	
	L <sub>1</sub>	L <sub>2</sub>	H	W	φD <sub>1</sub>	φD <sub>2</sub>	N	S303 S316	B
1/8M	21	—	12	—	11.5	—	7	11.5	12
1/4M	29	—	14	—	13.5	—	10.5	20	21.5
1/8F	27	—	12	—	11.5	—	7	18	19
1/4F	36.5	—	17	—	16	—	10.5	45	46
3/8F	45.5	6	—	17	—	20	11	70	74
1/2F	56	8	—	22	—	25	14	150	160
3/4F	73	10	—	27	—	32	15	300	320
1F	94	14	—	34	—	40	17	575	620
1½F	131	20	—	50	—	58	19	1,690	—
2F	168	24	—	60	—	70	23	2,910	—
2½F	199	27	—	80	—	90	27	5,860	—
3F	220	30	—	90	—	105	30	9,420	—

[Note] Appearance and dimensions may differ slightly depending on materials and nozzle codes.

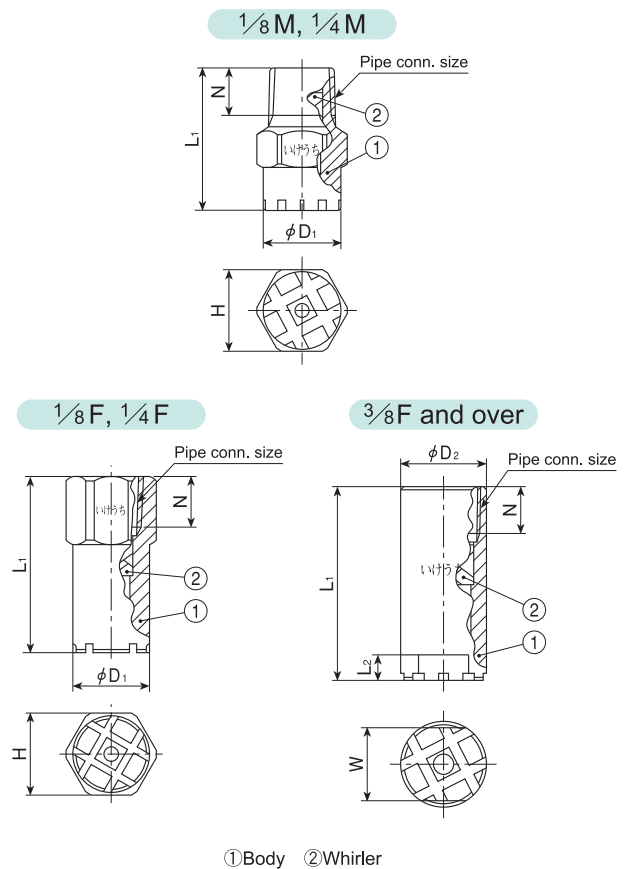

## SSXP-HTPVC series

SSXP-HTPVC series	
Structure	● One-piece structure with removable X-shaped whirler.
Material	● HTPVC (heat-treated polyvinyl chloride)
Mass	● 3.1 g

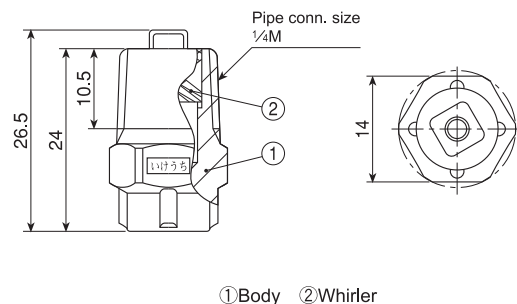

[Note] Appearance and dimensions may differ slightly depending on materials and nozzle codes.

# Square Spray Nozzles

## SSXP / SSXP-HTPVC series

### SSXP series

Spray Capacity Code	Pipe Conn. Size				Spray Angle (°)			Spray Capacity (ℓ/min)									Mean Drop. Dia. (μm)	Free Pass. Dia. (mm)
	1/8M	1/4M	3/8F	1/2F	0.05 MPa	0.2 MPa	0.5 MPa	0.03 MPa	0.05 MPa	0.1 MPa	0.15 MPa	0.2 MPa	0.3 MPa	0.5 MPa	0.7 MPa	1 MPa		
020	○		○		86	90	81	—	1.06	1.46	1.75	2.00	2.36	2.91	3.34	3.86	330	0.9
030	○		○		86	90	81	—	1.59	2.18	2.63	3.00	3.54	4.36	5.00	5.79	380	1.2
040		○		○	90	95	85	—	2.12	2.91	3.51	4.00	4.72	5.81	6.67	7.72	360	1.3
050		○		○	91	95	86	—	2.65	3.64	4.38	5.00	5.90	7.27	8.34	9.64	360	1.7
060		○		○	91	95	86	2.51	3.18	4.37	5.26	6.00	7.08	8.72	10.0	11.6	490	1.7

Spray Capacity Code	Pipe Conn. Size								Spray Angle (°)			Spray Capacity (ℓ/min)									Mean Drop. Dia. (μm)	Free Pass. Dia. (mm)
	3/8F	1/2F	3/4F	1F	1 1/2F	2F	2 1/2F	3F	0.05 MPa	0.2 MPa	0.5 MPa	0.03 MPa	0.05 MPa	0.1 MPa	0.15 MPa	0.2 MPa	0.3 MPa	0.5 MPa	0.7 MPa	1 MPa		
070	○								94	100	89	2.93	3.71	5.09	6.14	7.00	8.26	10.2	11.7	13.5	440	2.0
080	○								95	100	90	3.35	4.24	5.82	7.01	8.00	9.44	11.6	13.3	15.4	360	2.0
10	○								96	100	91	4.19	5.29	7.28	8.77	10.0	11.8	14.5	16.7	19.3	360	2.6
12	○								97	100	92	5.03	6.35	8.73	10.5	12.0	14.2	17.4	20.0	23.1	630	2.6
16		○							95	100	90	6.70	8.47	11.6	14.0	16.0	18.9	23.3	26.7	30.9	360	2.8
20		○							96	100	91	8.36	10.6	14.6	17.5	20.0	23.6	29.1	33.4	38.6	710	3.5
30			○						96	100	91	12.6	15.9	21.8	26.3	30.0	35.4	43.6	50.0	57.9	360	3.8
40			○						97	100	92	16.8	21.2	29.1	35.1	40.0	47.2	58.1	66.7	77.2	360	4.8
50				○					95	100	90	20.9	26.5	36.4	43.8	50.0	59.0	72.7	83.4	96.4	750	5.4
60				○					96	100	91	25.1	31.8	43.7	52.6	60.0	70.8	87.2	100	115	360	5.4
80				○					97	100	92	33.5	42.4	58.2	70.1	80.0	94.4	115	135	155	1,000	6.0
100					○				96	100	91	41.9	52.9	72.8	87.7	100	120	145	170	195	360	7.1
150					○				97	100	92	62.8	79.4	110	130	150	180	220	250	290	360	10.2
300						○			97	100	92	125	160	220	265	300	355	435	500	580	1,350	12.7
500							○		97	100	92	210	265	365	440	500	590	730	835	965	1,500	16.8
700								○	97	100	92	290	370	510	615	700	826	1,020	1,170	1,350	1,700	17.1

### SSXP-HTPVC series

Spray Angle (°)			Spray Capacity (ℓ/min)								Mean Drop. Dia. (μm)	Free Pass. Dia. (mm)
0.05 MPa	0.15 MPa	0.5 MPa	0.05 MPa	0.1 MPa	0.15 MPa	0.2 MPa	0.3 MPa	0.5 MPa	0.7 MPa	1 MPa		
56	65	65	2.72	3.74	4.50	5.14	6.06	7.46	8.56	9.90	450	2.2

### How to order

Please inquire or order for a specific nozzle using this coding system.

#### ① SSXP series (metal)

<Example>...1/8MSSXP020S303

1/8M	SSXP	020	S303
<small>Pipe Conn. Size</small>		<small>Spray Capacity Code</small>	<small>Material</small>
1/8M		020	S303
3F		700	S316

#### ② SSXP-HTPVC series (plastic)

1/4MSSXP 1.5 <sup>65</sup>/<sub>4.5</sub> HTPVC